

ADVANCE INFORMATION SUBJECT TO CHANGE

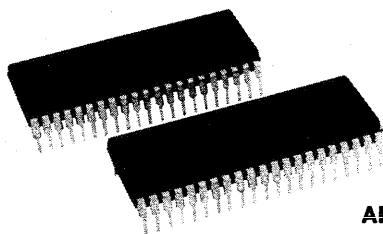

PCM64P

ADVANCE INFORMATION
Subject to Change

18-Bit Audio DIGITAL-TO-ANALOG CONVERTER

FEATURES

- 18-BIT MONOLITHIC AUDIO D/A CONVERTER
- LOW -96dB MAX THD+N AT FS (16-BIT LINEARITY WITH EXTERNAL ADJUST)
- VERY FAST SETTLING CURRENT OUTPUT (200ns)
- PARALLEL INPUTS, 42-PIN PLASTIC "SHRINK" DIP
- USER PROVIDES 10V REFERENCE AND OP AMP TO OPTIMIZE COST EFFECTIVENESS
- -15V , $+5\text{V}$ SUPPLIES, 415mW POWER DISSIPATION

APPLICATIONS

- HIGH ACCURACY DIRECT DIGITAL WAVEFORM SYNTHESIS
- PROFESSIONAL AND HIGH END DIGITAL AUDIO

DESCRIPTION

The PCM64JP/KP is a precision 18-bit digital-to-analog converter that features 16-bit linearity and ultra low distortion over a very wide frequency range. It is based on the highly accurate and stable 18-bit DAC729. The PCM64P greatly reduces cost by allowing the user to supply an external reference and current-to-voltage converter. This enables optimum cost/performance designs to be achieved when the very good temperature drift and stability specifications of the DAC729 are not necessarily required.

The PCM64P comes in a 42-pin double-wide plastic "shrink" DIP package. Applications include very low distortion frequency synthesis and very high end consumer and professional digital audio applications.

International Airport Industrial Park • P.O. Box 11400 • Tucson, Arizona 85734 • Tel.: (602) 746-1111 • Twx: 910-952-1111 • Cable: BBRCORP • Telex: 66-6491

PDS-786

SPECIFICATIONS

ELECTRICAL

All specifications at +25°C, +V_{DD} = +5.00V, and -V_{CC} = -15.0V unless otherwise noted.

PARAMETER	CONDITIONS	PCM64P			UNITS
		MIN	TYP	MAX	
RESOLUTION				18	Bits
DYNAMIC RANGE			108		dB
INPUT					
DIGITAL INPUT Logic Family Logic Level: V _{IH} V _{IL} Data Format	I _{IH} = +10μA I _{IL} = -300μA	TTL Compatible +2.4 0.0 +5.25 +0.8 Parallel CSB, COB, CTC ⁽¹⁾			V V
DYNAMIC CHARACTERISTICS					
TOTAL HARMONIC DISTORTION + NOISE ⁽²⁾ F = 991Hz (0dB) F = 991Hz (-20dB) F = 991Hz (-60dB)	F _s = 176.4kHz with external bits 1-4 adjust ⁽³⁾		-100 -86 -46	-96 -82 -42	dB dB dB
TOTAL HARMONIC DISTORTION + NOISE F = 991Hz (0dB) F = 991Hz (-20dB) F = 991Hz (-60dB)	F _s = 176.4kHz without external bits adjust		-96 -78 -38	-93 -76 -36	dB dB dB
NOISE	20Hz to 20kHz at bipolar zero			3	nArms
TRANSFER CHARACTERISTICS					
ACCURACY Gain Error Bipolar Zero Error				±0.5 ±6.0	% μA
DRIFT Gain Bipolar Zero	0°C to +70°C 0°C to +70°C		±10 ±2		ppm/°C ppm of FSR/°C
POWER SUPPLY SENSITIVITY +V _{CC} -V _{CC} +V _{DD}			±0.003 ±0.003 ±0.001		%FSR/%V _{CC} %FSR/%V _{CC} %FSR/%V _{DD}
WARM-UP TIME				1	minute
OUTPUT					
ANALOG OUTPUT Output Range ⁽⁴⁾ Internal R _{FEEDBACK} Output Impedance		-1.00 10k, 10k, 5k, 5k 3.0		+1.00	mA Ω kΩ
SETTLING TIME 1mA Step	10Ω to 100Ω load		200		ns
REFERENCE REQUIREMENTS					
REFERENCE INPUT Input Voltage Input Current Input Current	Unipolar Bipolar	9.9	10	10.1 1 2	V mA mA
POWER SUPPLY REQUIREMENTS					
Voltage Range: -V _{CC} +V _{DD} Current: -V _{CC} +V _{DD} Power Dissipation	-V _{CC} = -15V, V _{DD} = +5V	-14.5 +4.75	-22 +17 415	-15.5 +5.25	V V mA mA mW
TEMPERATURE RANGE					
Specification Storage		0 -50		+70 +100	°C °C

NOTES: (1) CTC code requires external inversion of MSB bit input. (2) Ratio of Distortion rms + Noise rms/Signal rms. (3) F_s = Sample rate of DAC (4 × 44.1kHz). (4) Tolerance of I_{OUT} and R_{FEEDBACK} is approximately ±1%.

PCM64P

AUDIO, COMMUNICATIONS, DSP D/A CONV.

MECHANICAL

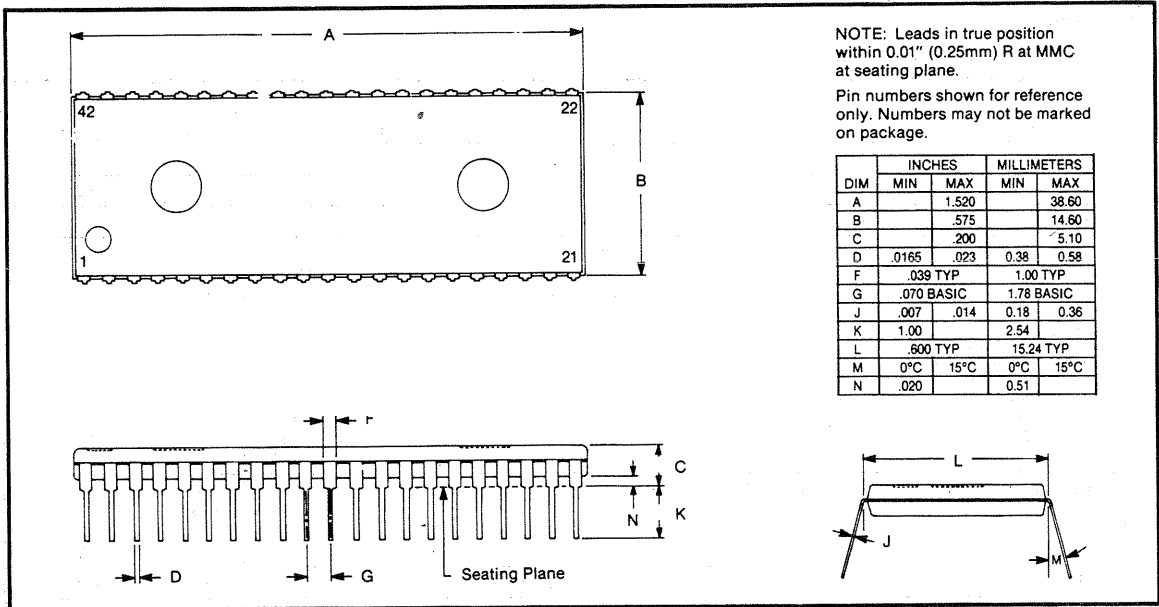

OUTPUT DEGLITCHING CIRCUITRY

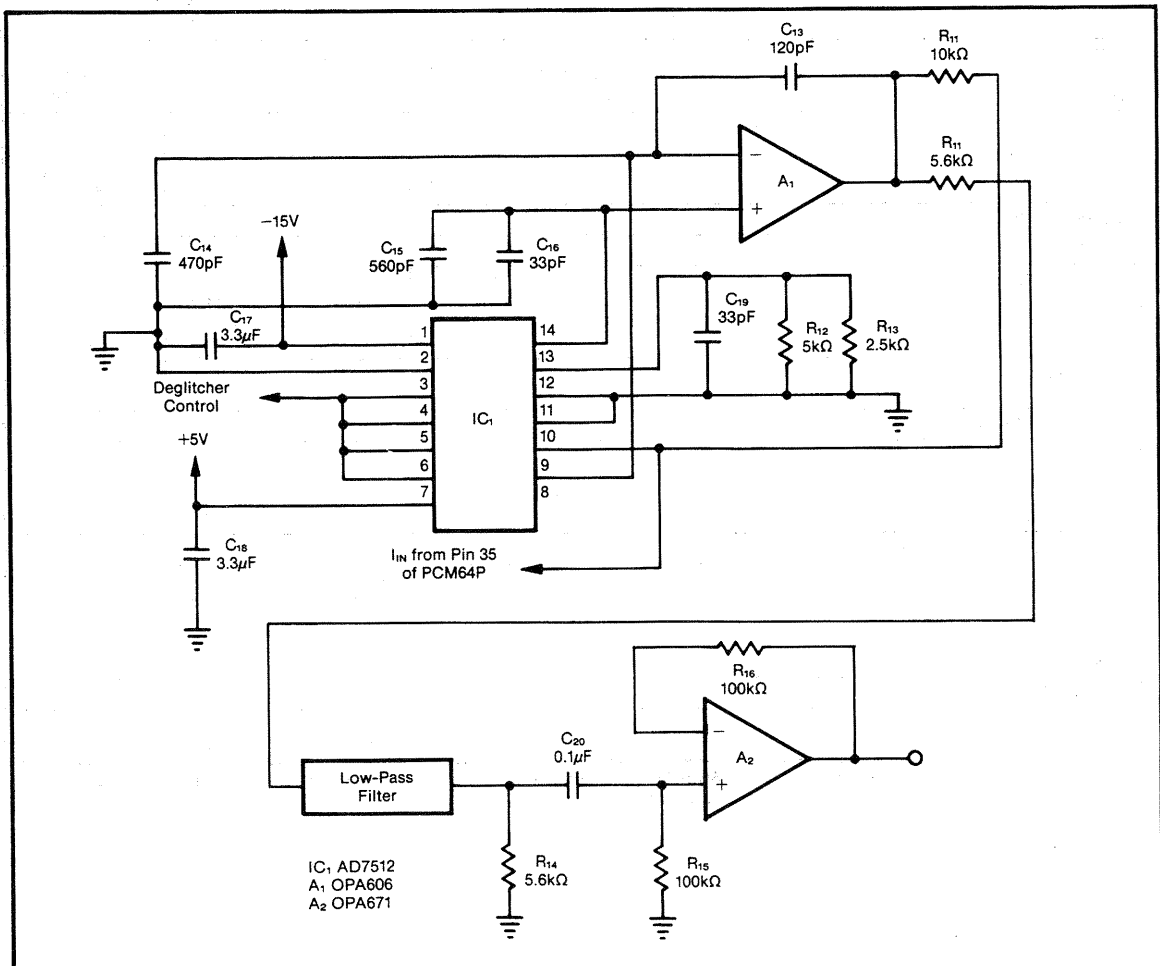

CONNECTION DIAGRAM

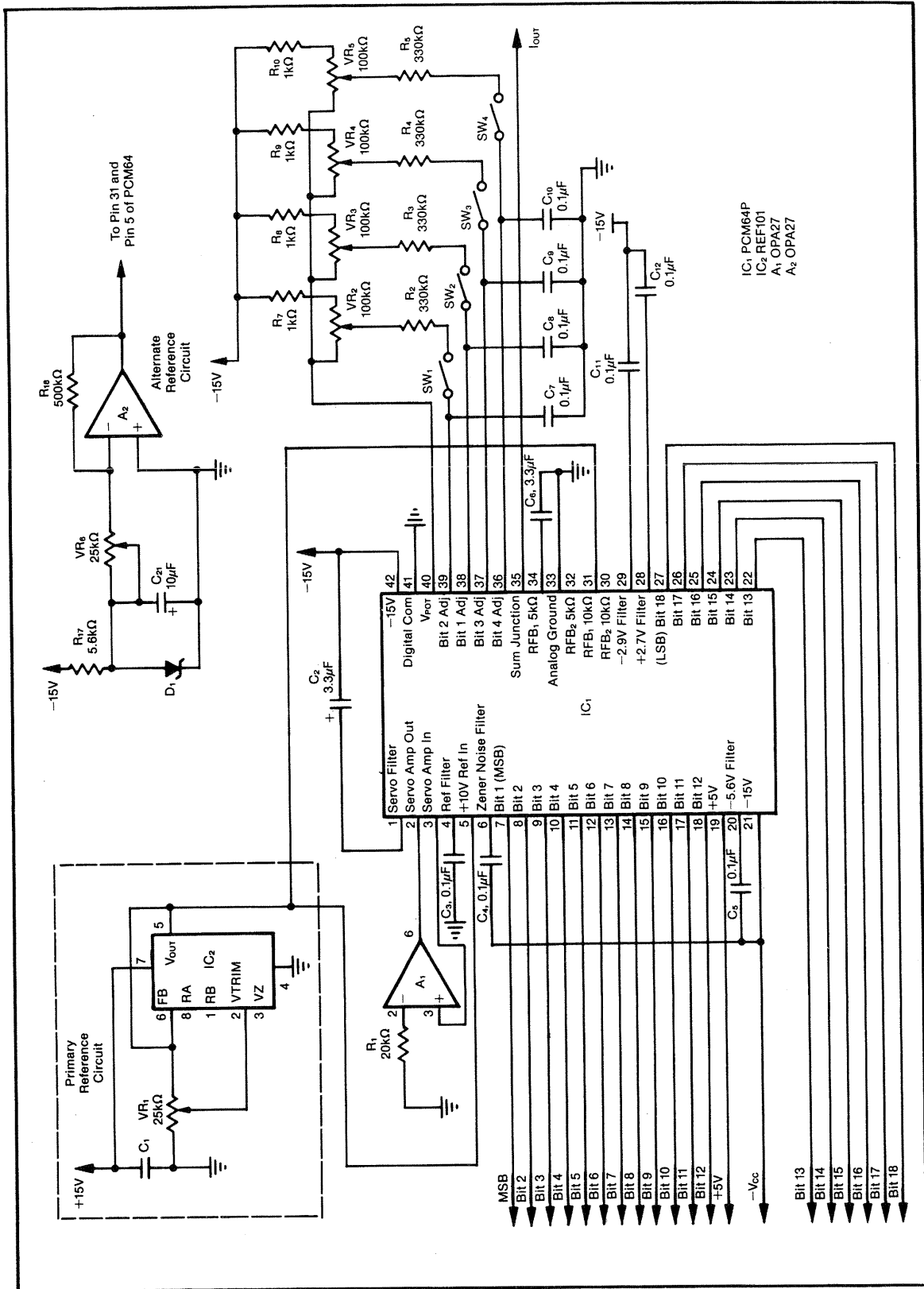

PCM64P

AUDIO, COMMUNICATIONS, DSP D/A CONV.