

Miniature ceramic plate capacitors

Class 1, 100 V (DC) (flanged types)

FEATURES

- High-frequency circuits
- Temperature compensating
- High stability
- Space saving.

APPLICATIONS

In a great variety of electronic circuits, e.g. in filters and tuning circuits where high stability and/or temperature compensation are a requirement. Because of their small size the capacitors are suitable for use in circuitry with high component density.

DESCRIPTION

The capacitors consist of a thin rectangular ceramic plate, both sides of which are metallized, and tinned connecting leads are secured using a high melting point solder. The capacitors are encapsulated in epoxy lacquer, which is resistant to all commonly used cleaning solvents. They have small dimensions and narrow tolerances on the lead spacing. The leads are provided with a flange, which guarantees that the leads are free of lacquer, and its shape allows soldering gasses to escape freely, ensuring excellent solderability. This makes the capacitors suitable for both hand-mounting and automatic insertion. The electrical properties are characterized by low losses, a narrow tolerance on capacitance (± 0.25 pF or 2%), high stability and, owing to the absence of silver, an extremely good DC behaviour.

QUICK REFERENCE DATA

DESCRIPTION	VALUE
Capacitance range (E12 series)	0.56 to 560 pF
Rated DC voltage	100 V
Tolerance on capacitance	$\pm 2\%$ or ± 0.25 pF
Temperature coefficients	P100, NP0, N150, N750 and N1500; note 1
Sectional specification	IEC 384-8
Climatic category (IEC 68)	55/085/21 (N150, N750); 55/125/56 (P100, NP0, N1500)

Note

1. N075, N220, N330, N470 available on request.

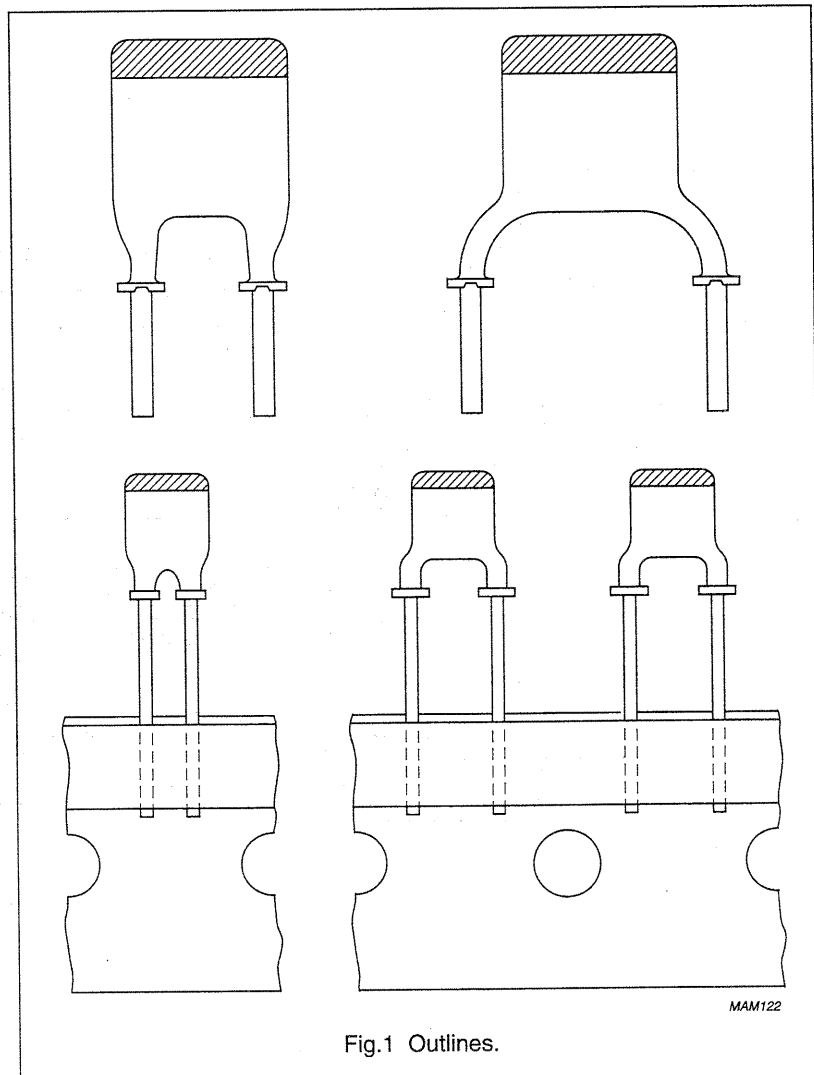

Fig.1 Outlines.

MAM122

Miniature ceramic plate capacitors

Class 1, 100 V (DC)
(flanged types)

MECHANICAL DATA

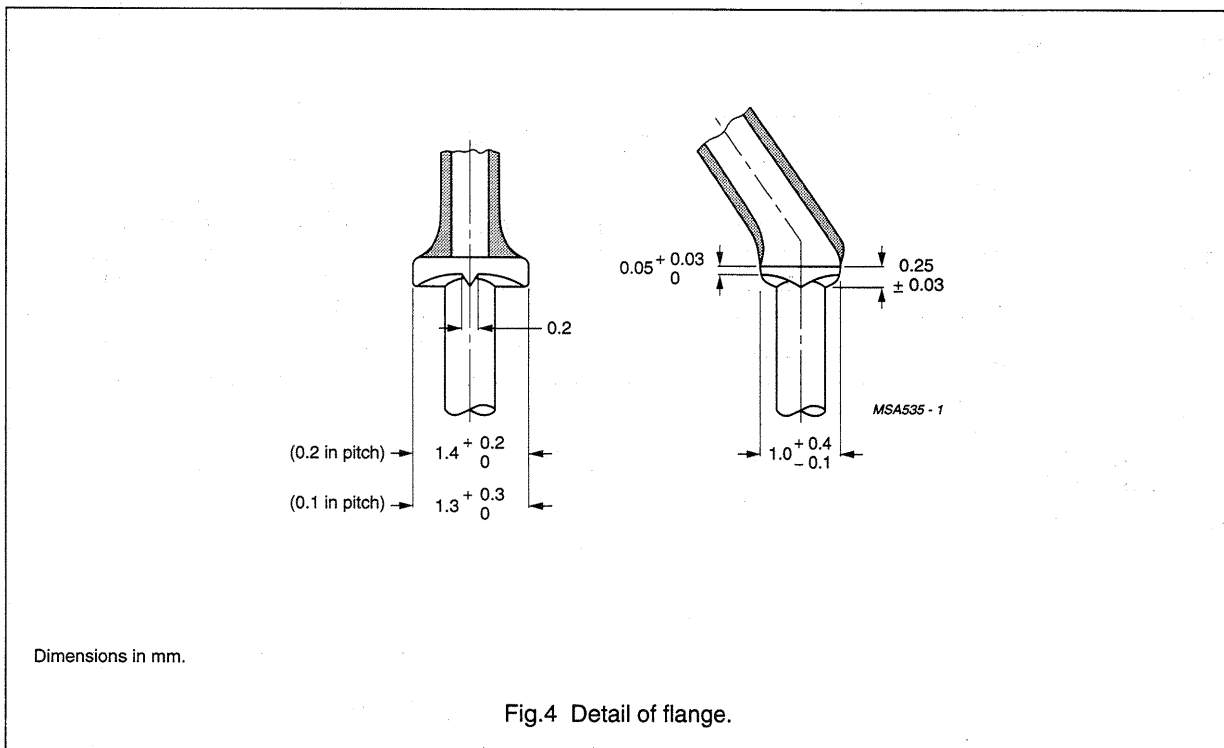
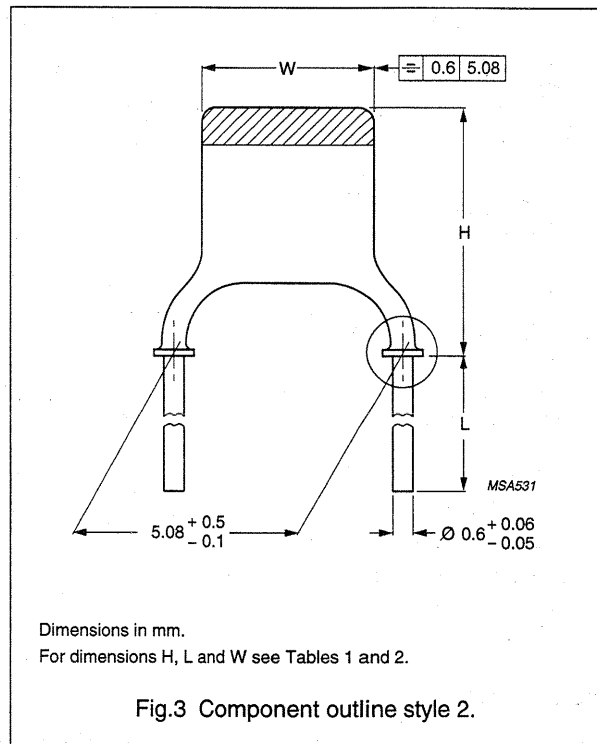
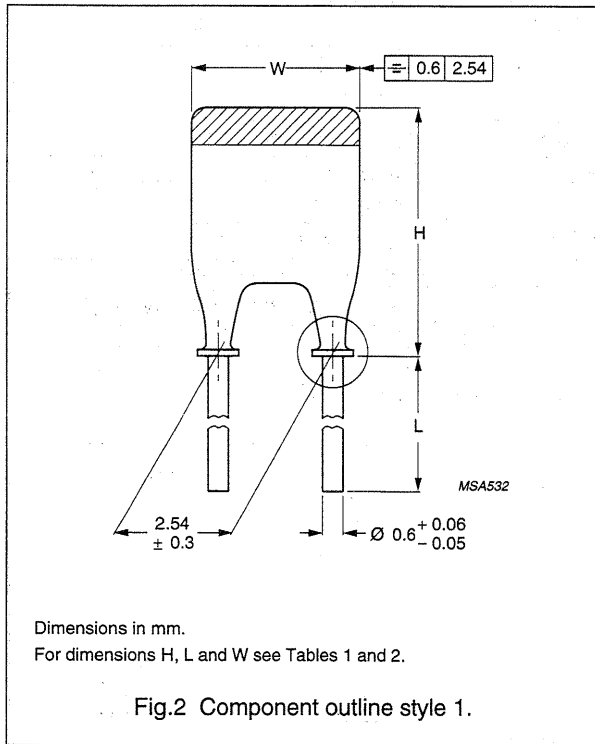

Miniature ceramic plate capacitors

Class 1, 100 V (DC) (flanged types)

Marking

The temperature coefficient is indicated by a colour code in accordance with IEC and EIA recommendations. Capacitance value is indicated by a marking code in a contrasting colour on the body. Refer to Tables 3 to 12, for colour and marking codes.

Mounting

When bending, cutting or flattening, the leads should be relieved of the applied load by supporting them at the capacitor body.

Soldering conditions:

max. 265 °C, max. 10 s.

The capacitors are suitable for mounting on printed-circuit boards (hand-mounting or automatic insertion).

PACKAGING

For details refer to this handbook, Chapter "Miniature ceramic plate capacitors", Section "General data".

ORDERING INFORMATION

Table 2 Catalogue numbers

PITCH P	LEAD DIAMETER d	STYLE	CATALOGUE NUMBERS ⁽¹⁾			
			BULK PACKED		ON TAPE ⁽²⁾ (REEL)	ON TAPE ⁽²⁾ (AMMOPACK)
			L ≥ 13 mm	L = 4 ±0.5 mm		
2.54 mm (0.1 inch)	0.6 mm (0.024 inch)	1	2222 680	2222 682	2222 678	2222 688
5.08 mm (0.2 inch)	0.6 mm (0.024 inch)	2	2222 681	2222 683	2222 679	2222 689

Notes

- Catalogue numbers to be completed by adding the last 5-digit suffix for required capacitance value, see Tables 4 to 12.
- H₀ = 18.25 mm.

Physical dimensions

Table 1 Capacitor dimensions and mass

SIZE ⁽¹⁾	W ⁽²⁾ (mm)	H ⁽²⁾ (mm)		MASS (g)
		STYLE 1	STYLE 2	
I	3.6 (-1.1)	5.0 (-1.5)	6.3 (-1.8)	≈0.14
IIA	3.9 (-1.4)	5.3 (-1.7)	6.7 (-2.0)	≈0.15
IIB	4.5 (-1.8)	6.0 (-2.1)	7.3 (-2.4)	≈0.15
III	5.3 (-1.8)	6.8 (-2.3)	8.1 (-2.6)	≈0.17
IV	6.2 (-2.0)	7.7 (-2.4)	9.0 (-2.7)	≈0.20
V	6.2 (-2.0)	10.3 (-2.8)	11.2 (-3.1)	≈0.23

Notes

- Unless indicated in Tables 4 to 12, the thickness of the capacitors does not exceed 2.3 mm.
- Tolerances are given between parentheses.

Miniature ceramic plate capacitors

Class 1, 100 V (DC)
(flanged types)**Table 3** Conditions for Table 4; capacitors with temperature coefficient **P100 (M7G)**, rated voltage 100 V (DC)

DESCRIPTION	VALUE
Capacitance range	0.56 to 47 pF (E12 series)
Temperature coefficient of the capacitance $\left(\frac{\Delta C}{C \Delta T}\right)$	$100 \times 10^{-6}/K$
Tolerance on the temperature coefficient	$\pm 30 \times 10^{-6}/K$
Marking colour of the temperature coefficient	red/violet
Climatic category (IEC 68)	55/125/56

Table 4 Preferred capacitance range, temperature coefficient **P100 (M7G)**

CAPACITANCE VALUE ⁽¹⁾ (pF)	TOLERANCE	SIZE (see Table 1)	MARKING	SUFFIX OF CATALOGUE NUMBER (see Table 2)
0.56	±0.25 pF	I ⁽²⁾	p56	03567
0.68	±0.25 pF	I ⁽²⁾	p68	03687
0.82	±0.25 pF	I ⁽²⁾	p82	03827
1.0	±0.25 pF	I ⁽³⁾	1p0	03108
1.2	±0.25 pF	I	1p2	03128
1.5	±0.25 pF	I	1p5	03158
1.8	±0.25 pF	I	1p8	03188
2.2	±0.25 pF	I	2p2	03228
2.7	±0.25 pF	I	2p7	03278
3.3	±0.25 pF	I	3p3	03338
3.9	±0.25 pF	I	3p9	03398
4.7	±0.25 pF	I	4p7	03478
5.6	±0.25 pF	I	5p6	03568
6.8	±0.25 pF	I	6p8	03688
8.2	±0.25 pF	IIA	8p2	03828
10	±2%	IIA	10p	04109
12	±2%	IIB	12p	04129
15	±2%	IIB	15p	04159
18	±2%	III	18p	04189
22	±2%	III	22p	04229
27	±2%	IV	27p	04279
33	±2%	IV	33p	04339
39	±2%	V	39p	04399
47	±2%	V	47p	04479

Notes

1. Other capacitance values and tolerances are available on request.
2. Maximum thickness 2.7 mm.
3. Maximum thickness 2.5 mm.

Miniature ceramic plate capacitors

Class 1, 100 V (DC)
(flanged types)**Table 5** Conditions for Table 6; capacitors with temperature coefficient **NP0 (C0G)**, rated voltage 100 V (DC)

DESCRIPTION	VALUE
Capacitance range	1.8 to 220 pF (E12 series)
Temperature coefficient of the capacitance $\left(\frac{\Delta C}{C\Delta T}\right)$	$0 \times 10^{-6}/K$
Tolerance on the temperature coefficient	$\pm 30 \times 10^{-6}/K$
Marking colour of the temperature coefficient	black
Climatic category (IEC 68)	55/125/56

Table 6 Preferred capacitance range, temperature coefficient **NP0 (C0G)**

CAPACITANCE VALUE ⁽¹⁾ (pF)	TOLERANCE	SIZE (see Table 1)	MARKING	SUFFIX OF CATALOGUE NUMBER (see Table 2)
1.8	±0.25 pF	I ⁽²⁾	1p8	09188
2.2	±0.25 pF	I	2p2	09228
2.7	±0.25 pF	I	2p7	09278
3.3	±0.25 pF	I	3p3	09338
3.9	±0.25 pF	I	3p9	09398
4.7	±0.25 pF	I	4p7	09478
5.6	±0.25 pF	I	5p6	09568
6.8	±0.25 pF	I	6p8	09688
8.2	±0.25 pF	I	8p2	09828
10	±2%	I	10p	10109
12	±2%	I	12p	10129
15	±2%	I	15p	10159
18	±2%	I	18p	10189
22	±2%	I	22p	10229
27	±2%	I	27p	10279
33	±2%	I	33p	10339
39	±2%	IIA	39p	10399
47	±2%	IIA	47p	10479
56	±2%	IIA	56p	10569
68	±2%	IIB	68p	10689
82	±2%	IIB	82p	10829
100	±2%	III	n10	10101
120	±2%	III	n12	10121
150	±2%	IV	n15	10151
180	±2%	IV	n18	10181
220	±2%	V	n22	10221

Notes

1. Other capacitance values and tolerances are available on request.
2. Maximum thickness 2.5 mm.

Miniature ceramic plate capacitors

Class 1, 100 V (DC)
(flanged types)**Table 7** Conditions for Table 8; capacitors with temperature coefficient **N150 (P2G)**, rated voltage 100 V (DC)

DESCRIPTION	VALUE
Capacitance range	3.9 to 220 pF (E12 series)
Temperature coefficient of the capacitance $\left(\frac{\Delta C}{C\Delta T}\right)$	$-150 \times 10^{-6}/K$
Tolerance on the temperature coefficient	$\pm 30 \times 10^{-6}/K$
Marking colour of the temperature coefficient	orange
Climatic category (IEC 68)	55/085/21

Table 8 Preferred capacitance range, temperature coefficient **N150 (P2G)**

CAPACITANCE VALUE ⁽¹⁾ (pF)	TOLERANCE	SIZE (see Table 1)	MARKING	SUFFIX OF CATALOGUE NUMBER (see Table 2)
3.9	±0.25 pF	I ⁽²⁾	3p9	33398
4.7	±0.25 pF	I	4p7	33478
5.6	±0.25 pF	I	5p6	33568
6.8	±0.25 pF	I	6p8	33688
8.2	±0.25 pF	I	8p2	33828
10	±2%	I	10p	34109
12	±2%	I	12p	34129
15	±2%	I	15p	34159
18	±2%	I	18p	34189
22	±2%	I	22p	34229
27	±2%	I	27p	34279
33	±2%	I	33p	34339
39	±2%	IIA	39p	34399
47	±2%	IIA	47p	34479
56	±2%	IIB	56p	34569
68	±2%	IIB	68p	34689
82	±2%	III	82p	34829
100	±2%	III	n10	34101
120	±2%	IV	n12	34121
150	±2%	IV	n15	34151
180	±2%	IV	n18	34181
220	±2%	V	n22	34221

Notes

1. Other capacitance values and tolerances are available on request.
2. Maximum thickness 2.5 mm.

Miniature ceramic plate capacitors

Class 1, 100 V (DC)
(flanged types)**Table 9** Conditions for Table 10; capacitors with temperature coefficient **N750 (U2J)**, rated voltage 100 V (DC)

DESCRIPTION	VALUE
Capacitance range	3.9 to 330 pF (E12 series)
Temperature coefficient of the capacitance $\left(\frac{\Delta C}{C \Delta T}\right)$	$-750 \times 10^{-6}/K$
Tolerance on the temperature coefficient	$\pm 120 \times 10^{-6}/K$
Marking colour of the temperature coefficient	violet
Climatic category (IEC 68)	55/085/21

Table 10 Preferred capacitance range, temperature coefficient **N750 (U2J)**

CAPACITANCE VALUE ⁽¹⁾ (pF)	TOLERANCE	SIZE (see Table 1)	MARKING	SUFFIX OF CATALOGUE NUMBER (see Table 2)
3.9	±0.25 pF	I ⁽²⁾	3p9	57398
4.7	±0.25 pF	I	4p7	57478
5.6	±0.25 pF	I	5p6	57568
6.8	±0.25 pF	I	6p8	57688
8.2	±0.25 pF	I	8p2	57828
10	±2%	I	10p	58109
12	±2%	I	12p	58129
15	±2%	I	15p	58159
18	±2%	I	18p	58189
22	±2%	I	22p	58229
27	±2%	I	27p	58279
33	±2%	I	33p	58339
39	±2%	I	39p	58399
47	±2%	I	47p	58479
56	±2%	IIA	56p	58569
68	±2%	IIA	68p	58689
82	±2%	IIB	82p	58829
100	±2%	IIB	n10	58101
120	±2%	III	n12	58121
150	±2%	III	n15	58151
180	±2%	IV	n18	58181
220	±2%	IV	n22	58221
270	±2%	V	n27	58271
330	±2%	V	n33	58331

Notes

- Other capacitance values and tolerances are available on request.
- Maximum thickness 2.5 mm.

Miniature ceramic plate capacitors

Class 1, 100 V (DC)
(flanged types)**Table 11** Conditions for Table 12; capacitors with temperature coefficient **N1500 (P3K)**, rated voltage 100 V (DC)

DESCRIPTION	VALUE
Capacitance range	18 to 560 pF (E12 series)
Temperature coefficient of the capacitance $\left(\frac{\Delta C}{C \Delta T}\right)$	$-1500 \times 10^{-6}/K$
Tolerance on the temperature coefficient	$(0 \text{ to } +500) \times 10^{-6}/K$
Marking colour of the temperature coefficient	orange/orange
Climatic category (IEC 68)	55/125/56

Table 12 Preferred capacitance range, temperature coefficient **N1500 (P3K)**

CAPACITANCE VALUE ⁽¹⁾ (pF)	TOLERANCE	SIZE (see Table 1)	MARKING	SUFFIX OF CATALOGUE NUMBER (see Table 2)
18	±2%	I ⁽²⁾	18p	70189
22	±2%	I	22p	70229
27	±2%	I	27p	70279
33	±2%	I	33p	70339
39	±2%	I	39p	70399
47	±2%	I	47p	70479
56	±2%	I	56p	70569
68	±2%	I	68p	70689
82	±2%	I	82p	70829
100	±2%	IIA	n10	70101
120	±2%	IIA	n12	70121
150	±2%	IIB	n15	70151
180	±2%	IIB	n18	70181
220	±2%	III	n22	70221
270	±2%	III	n27	70271
330	±2%	IV	n33	70331
390	±2%	IV	n39	70391
470	±2%	V	n47	70471
560	±2%	V	n56	70561

Notes

1. Other capacitance values and tolerances are available on request.
2. Maximum thickness 2.5 mm.

Miniature ceramic plate capacitors

Class 1, 100 V (DC)
(flanged types)**ELECTRICAL CHARACTERISTICS**

The capacitors meet the essential requirements of "IEC 384-8". Unless stated otherwise all electrical values apply at an ambient temperature of 20 ± 1 °C, an atmospheric pressure of 86 to 106 kPa and a relative humidity of 63 to 67%.

DESCRIPTION	VALUE
Capacitance values (note 1) measured at 1 MHz, ≤ 5 V	see Tables 4 to 12
Rated DC voltage	100 V
DC test voltage; duration 1 minute	300 V
DC test voltage of coating; duration 1 minute	300 V
Insulation resistance at 100 V (DC) after 1 minute	$\geq 10000 \text{ M}\Omega$
Tan δ (note 1) measured at 1 MHz, ≤ 5 V:	
C ≤ 50 pF	$\leq 15 \left(\frac{15}{C} + 0.7 \right) \times 10^{-4}$; $< 55 \times 10^{-4}$
C > 50 pF	$\leq 15 \times 10^{-4}$
Category temperature range	-55 to +85 °C (N150, N750); -55 to +125 °C (P100, NP0, N1500)
Storage temperature range	-55 to +85 °C

Note

- Including 2 mm per connecting lead.

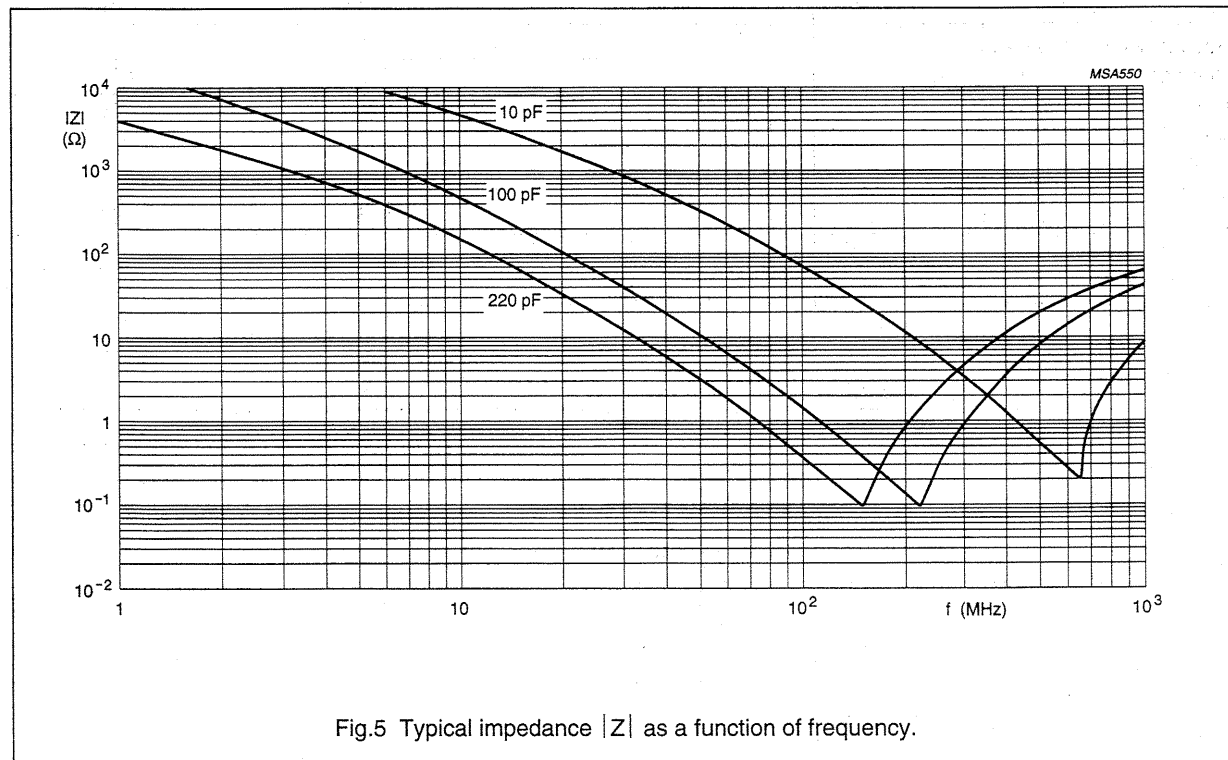

Fig.5 Typical impedance $|Z|$ as a function of frequency.