

Universal Transducer Interface (UTI) Revolution in Sensor Interfacing

Features

- Provides interfacing for many types of sensor elements: capacitors, platinum resistors, thermistors, resistive bridges and potentiometers
- Measurement of multiple sensor elements
- Single 2.9 V - 5.5 V power supply, current consumption below 2.5 mA
- Resolution and linearity up to 14 bits and 13 bits
- Continuous auto-calibration of offset and gain
- Microcontroller-compatible output signal
- Tri-state output
- Typical measurement time 10 ms or 100 ms
- 2/3/4-wire measurement available for almost all measurements
- AC excitation voltage signal for all sensor elements
- Suppression of 50/60 Hz interference.
- Power down mode
- Temperature range -40°C to 85°C
- Die operating temperature up to 180°C

1. General Description

The Universal Transducer Interface (UTI) is a complete analog front end for low frequency measurement applications, based on a period-modulated oscillator. Sensing elements can be directly connected to the UTI without the need for extra electronics. Only a single reference element, of the same kind as the sensor, is required. The UTI outputs a microcontroller-compatible period-modulated signal. The UTI can provide interfacing for:

- Capacitive sensors 0 - 2 pF, 0 -12 pF, variable range up to 300 pF
- Platinum resistors Pt100, Pt1000
- Thermistors 1 kΩ - 25 kΩ
- Resistive bridges 250 Ω - 10 kΩ with maximum imbalance +/- 4% or +/- 0.25%
- Potentiometers 1 kΩ - 50 kΩ
- Combinations of the above mentioned

The UTI is ideal for use in smart microcontroller-based systems. One output-data wire reduces the number of interconnect lines and reduces the number of opto-couplers required in isolated systems. Continuous auto-calibration of offset and gain of the complete system is performed by using the three-signal technique. The low-

frequency interference is removed by using an advanced chopping technique. The function selection can be configured in both software and hardware.

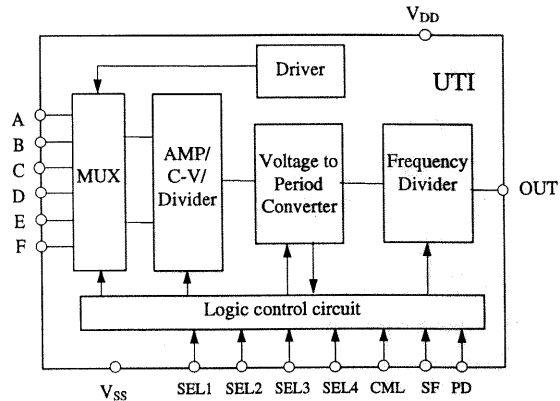

2. Pin-out and Ratings

The UTI is available in a 16-pin plastic dual-in-line package (DIP) as well as a 18-lead small outline package (SOIC). Figure 1 shows the pin configurations of DIP and SOIC. The function of the pins is listed in Table 1.

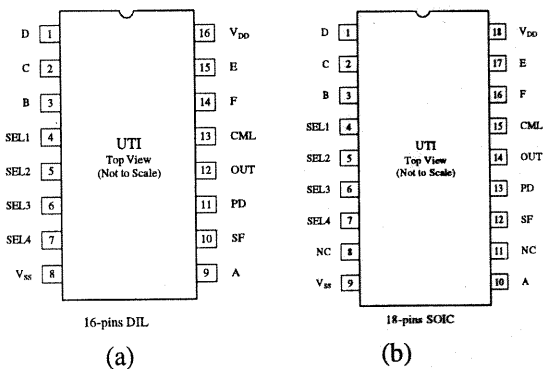

Figure 1 Pin configuration.

Name	Function of the pin
V _{DD} , V _{SS}	Power supply
A, B, C, D, E, F	Sensor connections
SEL1..SEL4	Mode selection (see Table 2)
OUT	Output
SF	Slow/fast mode selection
CML	CMUX02/CMUX12 mode selection
PD	Power down (tri-state)

Table 1. Function of the pins.

3. Absolute Maximum Ratings

$T_A = +25^\circ\text{C}$

Power supply voltage	-0.3 V to +7 V
Power supply current (excluding connection to the sensor)	3 mA
Power dissipation	21 mW
Power dissipation at power down	7 μW
Output voltage	-0.3 V to $V_{DD}+0.3$ V
Output current	8 mA
Output impedance	60 Ω
Input voltage ref. to V_{SS}	-0.3 V to $V_{DD}+0.3$ V
Input current on each pin	± 20 mA
ESD rating	> 4000 V
Storage temperature range	-65 $^\circ\text{C}$ to +150 $^\circ\text{C}$
Operating temperature range	-40 $^\circ\text{C}$ to +85 $^\circ\text{C}$
Lead temperature (soldering, 10 sec)	+300 $^\circ\text{C}$

4. General specifications

4.1 Functionality

SEL1	SEL2	SEL3	SEL4	Mode	No. of Phases	Name	Mode No.
0	0	0	0	5 Capacitors, 0-2pF	5	C25	0
0	0	0	1	3 Capacitors, 0-2pF	3	C23	1
0	0	1	0	5 Capacitors, 0-12pF	5	C12	2
0	0	1	1	Capacitors, 0-2pF, external MUX CML=0 Capacitors, 0-12pF, external MUX CML=1	-	CMUX	3
0	1	0	0	3 Capacitors, variable range to 300pF	3	C300	4
0	1	0	1	Platinum resistor Pt100-Pt1000, 4-wire	4	Pt	5
0	1	1	0	Thermistor 1k Ω -25k Ω , 4-wire	4	Ther	6
0	1	1	1	2 or 3 platinum resistors Pt100-Pt1000	5	Pt2	7
1	0	0	0	2 or 3 thermistors, 1k Ω -25k Ω ,	5	Ther2	8
1	0	0	1	Resistive bridge, ref. is V_{bridge} , +/- 200mV	3	Ub2	9
1	0	1	0	Resistive bridge, ref. is V_{bridge} , +/- 12.5mV	3	Ub1	10
1	0	1	1	Resistive bridge, ref. is I_{bridge} , +/- 200mV	3	Ib2	11
1	1	0	0	Resistive bridge, ref. is I_{bridge} , +/- 12.5mV	3	Ib1	12
1	1	0	1	Res. bridge and two resistors, +/- 200mV	5	Brg2	13
1	1	1	0	Res. bridge and two resistors, +/- 12.5mV	5	Brg1	14
1	1	1	1	3 Potentiometers 1k Ω -50k Ω	5	Potm	15

Table 2. Modes of the UTI, including the name of the modes and the number of phases within 1 cycle.

4.2 Three-signal technique and calibration

The three-signal technique is a technique to eliminate the effects of unknown offset and unknown gain in a linear system. In order to apply this technique, in addition to the measurement of the sensor signal, two reference signals are required to be measured in an identical way. Suppose a system has a linear transfer function of

$$M_i = kE_i + M_{\text{off}} \quad (1)$$

The measured three signals are

$$\begin{aligned} M_{\text{off}} &= M_{\text{off}} \\ M_{\text{ref}} &= kE_{\text{ref}} + M_{\text{off}} \\ M_x &= kE_x + M_{\text{off}} \end{aligned} \quad (2)$$

Then the measuring result is the ratio

$$M = \frac{M_x - M_{\text{off}}}{M_{\text{ref}} - M_{\text{off}}} = \frac{E_x}{E_{\text{ref}}} \quad (3)$$

When the system is linear, then in this ratio the influence of the unknown offset M_{off} and the unknown gain k of the measurement system is eliminated. This technique has been used in the UTI.

The implementation of the three-signal technique requires a memory: A microcontroller is used to perform the data storage and the calculations, and to digitize the

period-modulated signals. Such a system combining a sensing element (sensor), a signal-processing circuit, such as the UTI, and a microcontroller is called a microcontroller-based smart sensor system.

4.3 The measurement of sensing elements

As an example, Figure 2 shows two complete cycles of the output signal from the UTI, each consisting of three phases.

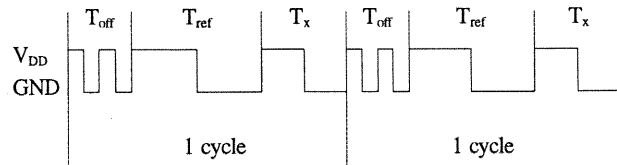

Figure 2. The output signal of the UTI for a 3-phase mode.

During the first phase T_{off} , the offset of the complete system is measured. During the second phase T_{ref} , the reference signal is measured and during the last phase T_x , the signal itself is measured. These phases are automatically controlled by the UTI itself.

The duration of each phase is proportional to the signal which is measured during that phase. The duration of the three phases is given by:

For capacitive measurement:	For resistive measurement:
$T_{off} = NK_1 C_0$	$T_{off} = NK_2 V_0$
$T_{ref} = NK_1 (C_{ref} + C_0)$	$T_{ref} = NK_2 (V_{ref} + V_0)$
$T_x = NK_1 (C_x + C_0)$	$T_x = NK_2 (V_x + V_0)$

where C_x or V_x is the sensor signal to be measured, C_{ref} or V_{ref} the reference signal, C_0 or V_0 a constant part (including offset voltages etc.) and K_1 or K_2 the gain. The factor N represents the number of internal oscillator periods in one phase. In slow mode, $N = 1024$ and in fast mode $N = 128$. The voltages V_x and V_{ref} are, for instance, the voltage across the sensor resistor and the reference resistor or V_x and V_{ref} represent the bridge output voltage and the bridge supply voltage, respectively.

The output signal of the UTI can be digitized by counting the number of internal clock cycles fitting in each phase. This results in the digital numbers N_{off} , N_{ref} and N_x . The ratio C_x/C_{ref} or V_x/V_{ref} can now be calculated by the microcontroller:

$$M = \frac{N_x - N_{off}}{N_{ref} - N_{off}} = \frac{C_x}{C_{ref}} \quad \text{or} \quad (4)$$

$$M = \frac{N_x - N_{off}}{N_{ref} - N_{off}} = \frac{V_x}{V_{ref}}$$

This ratio does not depend on the constant part and the gain. In fact, the system is calibrated for offset and gain.

Even in the case of drift or other slow variations of offset and gain, these effects are eliminated.

The three phases are time-multiplexed, as depicted in Figure 2. The offset phase is labeled, because it consists of two short intervals: the output frequency is temporarily doubled. This is recognized by the microcontroller, which guarantees that the correct calculation, as depicted in formula (4), is made.

The number of phases in a complete cycle varies between 3 and 5, depending on the mode.

4.4 Resolution.

The output signal of the UTI is digitized by the microcontroller. This sampling introduces quantization noise, which also limits the resolution. The quantization noise of a measurement phase, as given by the relative standard deviation σ_q , amounts to

$$\sigma_q = \frac{1}{\sqrt{6}} \frac{t_s}{T_{phase}} \quad (5)$$

where t_s is the sampling time and T_{phase} the phase duration. When the sampling time is $1 \mu s$ and the offset frequency is 50 kHz, the standard deviation of the offset phase is 12.5 bits in the fast mode and 15.5 bits in the slow mode.

Further improvement of the resolution can be obtained by averaging over several values of M . When P values $M_1 \dots M_P$ are used to calculate \bar{M} , the value of σ_q decreases with a factor of $P^{1/2}$.

Besides quantization noise, another limitation of the resolution is due to the thermal noise of the oscillator itself. In the fast mode, quantization noise is found to be the main noise source.

As an example,

Figure 3 depicts the measured resolution as a function of the measurement time, using the CMUX mode.

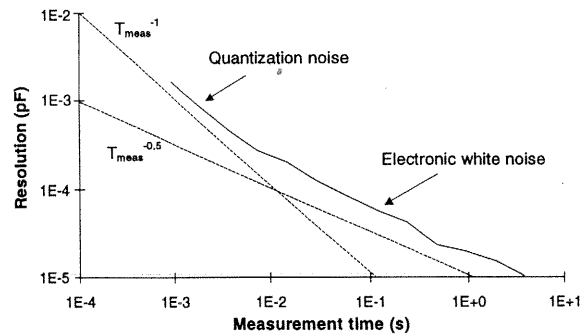

Figure 3 The resolution after the calculation required for the three-signal technique versus the total measurement time. The measurement range equals 0 - 2 pF and $C_p = 50$ pF (see Figure 7).

For the CMUX mode, the resolution as a function of the parasitic capacitance C_p (see Fig. 7) is shown in Figure 4.

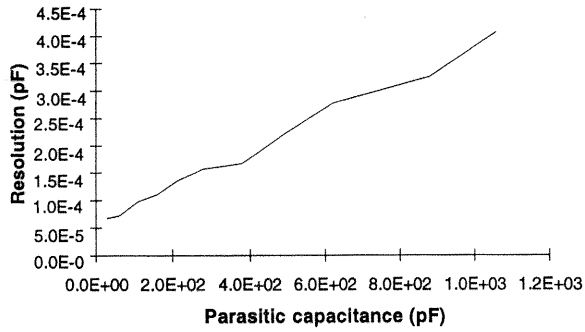

Figure 4 The resolution after the calculation required for the three-signal technique versus the parasitic capacitance C_p . The measurement range equals 0 - 2 pF.

For the CMUX mode, the nonlinearity as a function of the parasitic capacitance C_p (see Figure 7) is shown in Figure 5.

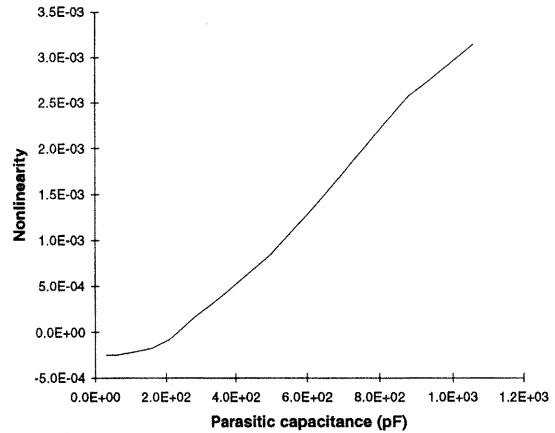

Figure 5 The nonlinearity versus the parasitic capacitance C_p . The measurement range equals 0 - 2 pF.

4.5 Linearity

Typically, the linearity of the UTI has values between 11 bits and 13 bits, depending on the mode.

5. Output

The UTI outputs a microcontroller-compatible period-modulated signal and excitation signals to drive the sensing elements. Table 3 shows some output specifications of the UTI.

($V_{DD} = 5\text{ V}$, $T_A = +25^\circ\text{C}$)

Parameter	Value	Unit	Conditions/Comments
V_{OL} , Output low voltage	0.4	V max	
V_{OH} , Output high voltage	$V_{DD}-0.6$	V min	
Output resistance at OUT	60	Ω	
Maximum load at OUT	8	mA	$V_{DD} = 5\text{ V}$
Output resistance at pins B, C, D, E and F	800	Ω	The pins B – F are used as output in the capacitive modes, 0 – 4.
Maximum output current from E and F	20	mA	For resistive and resistive-bridge modes
Rise time Fast mode	14	ns	
Slow mode	14	ns	
Fall time Fast mode	13	ns	
Slow mode	13	ns	
Intrinsic propagation delay time (PD-OUT) t_{PLH}	30	ms	These values are measured for the slow mode. For the fast mode, these values are 8 times smaller.
t_{PHL}	30	ms	
Intrinsic propagation delay time (SELi-OUT) t_{PLH}	30	ms	These values are measured for the slow mode. For the fast mode, these values are 8 times smaller.
t_{PHL}	30	ms	

Table 3 Some output specifications of the UTI.

6. Analog inputs

Various sensing elements can be directly connected to the inputs of the UTI. The connections of the sensing elements with the UTI for various modes are described in section 8. Table 4 shows some input specifications of the UTI.

($V_{DD} = 5\text{ V}$, $T_A = +25^\circ\text{C}$)

Parameter	Value	Unit	Conditions/Comments
Input capacitance	20	pF	
Capacitance leakage between A to B, C, D, E, F	30×10^{-3}	pF	DIP package
Suppression of 50/60 Hz	60	dB	

Table 4 Some input specifications of the UTI.

7. Control lines

As described in section 4.1, the UTI has 16 operating modes. These modes are selected by using four selection pins, SEL1, SEL2, SEL3 and SEL4. The mode selection can be performed in a software and a hardware way. In Table 2, a '1' corresponds to V_{DD} and '0' to GND. Some special functions are available, such as, slow/fast selection and power-down. These modes are set by SF and PD, respectively.

The pin SF is used to set the measurement speed. When SF = 1, the UTI is working in the fast mode. In this mode the duration of one complete cycle of the output signal is about 10 ms. When SF = 0, the UTI is working in the slow mode and the duration of one complete cycle of the output signal is about 100 ms.

The pin PD is used to set the power-down of the UTI. When PD = 0, the UTI is powered down and the output node is floating (high-impedance). This enables to connect several UTI outputs to a single output wire, provided that only a single UTI is selected (PD = 1).

The pin CML is always connected to GND except in mode CMUX. In mode CMUX, the pin CML is used for the measurement-range selection. These ranges are 0 - 2 pF (CML = 0) and 0 - 12 pF (CML = 1), respectively.

All digital and analog inputs are protected for ESD. Floating inputs are not allowed, unless otherwise stated.

8. Different modes

In this section, we specify the UTI properties for all modes. The names of these modes are the same as used in Table 2. In this section, CML = 0 and SF = 0 unless otherwise stated. Important parameters to be specified are:

- the accuracy,
- the resolution,
- the number of phases,
- the specified signals in the various phases.

The sequences of all phases are referred to the first one (phase 1). In this phase, the constant part (or offset) is measured. This phase also contains the synchronization for the microcontroller, since the output frequency in this phase is doubled.

During the described measurements, an Intel 87C51FA microcontroller with 3 MHz sampling frequency is used, but other types of microcontrollers can be used as well.

8.1 Mode 0. C25: 5 capacitors 0-2pF

In this mode, 5 capacitors in the range of 0 - 2 pF with one common electrode can be measured.

The connection of capacitors is depicted in Figure 6. The parasitic capacitance C_p is, for instance, the capacitance of the cables. All measured capacitors should have a common receiver electrode, connected to node A. The signal at the transmitting electrodes (B to F) is a square wave with amplitude V_{DD} . When a capacitor is not measured, the node corresponding to this capacitor is internally grounded. In mode C25, one cycle takes 5 measurement phases as depicted in Table 5.

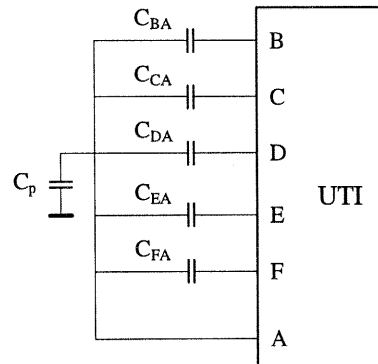

Figure 6. Connection of capacitors to the UTI.

Phase	Measured capacitors	Output periods
1	$C_{BA} + C_0$	$T_{BA} = NK_1(C_{BA} + C_0)$
2	$C_{CA} + C_0$	$T_{CA} = NK_1(C_{CA} + C_0)$
3	$C_{DA} + C_0$	$T_{DA} = NK_1(C_{DA} + C_0)$
4	$C_{EA} + C_0$	$T_{EA} = NK_1(C_{EA} + C_0)$
5	$C_{FA} + C_0$	$T_{FA} = NK_1(C_{FA} + C_0)$

Table 5. Measured capacitors during each phase.

In phase 1 the input capacitor $C_{BA} + C_0$ is measured. In this phase the output frequency is doubled, resulting in two short periods. This enables synchronization of the microcontroller. Generally, no capacitor is connected between B and A. The specifications for the mode C25 (mode 0) are listed in Table 6.

Parameter	Typical value
K_1	10 $\mu\text{s/pF}$
C_0	2 pF
Maximum capacitance C_{iA}	2 pF
Linearity	13 bits
Resolution (SF = 0, $C_p = 30$ pF)	14 bits
Remaining offset	$< 15 \times 10^{-3}$ pF

Table 6. Specifications of the C25 and C23 modes.

The remaining offset capacitance is caused by the parasitics between bonding wires, bonding pads and IC pins. When this offset is too large, one should use the mode CMUX. In this case, an external multiplexer is used and offset can be as low as 20×10^{-6} pF.

8.2 Mode 1. C23: 3 capacitors 0-2pF

In this mode, 3 capacitors in the range of 0 - 2 pF with one common electrode can be measured. The difference with mode C25 is that one cycle consists of only 3 phases. The connection of the capacitors is shown in Figure 6, where C_{EA} and C_{FA} are omitted now. The measured capacitors during each phase are listed in Table 7. The specifications are listed in Table 6.

Phase	Measured capacitors	Output periods
1	$C_{BA}+C_0$	$T_{BA} = NK_1(C_{BA} + C_0)$
2	$C_{CA}+C_0$	$T_{CA} = NK_1(C_{CA} + C_0)$
3	$C_{DA}+C_0$	$T_{DA} = NK_1(C_{DA} + C_0)$

Table 7. Measured capacitors during each phase of the mode C23.

8.3 Mode 2. C12: 5 capacitors 0-12pF

In this mode, 5 capacitors in the range of 0 - 12 pF with one common electrode can be measured. The connection of the capacitors to the UTI is shown in Figure 6. The maximum value of the capacitance C_{iA} (i is B, C, D or E) is 12 pF. The number of phases is 5. The specifications are listed in Table 8. The measured capacitors during each phase are indicated in Table 5. The main difference with mode 0 is that the maximum measurable capacitance is 12 pF.

Parameter	Typical value
K_1	1.7 $\mu\text{s/pF}$
C_0	12 pF
Maximum capacitance C_{iA}	12 pF
Linearity	13 bits
Resolution (SF = 0, $C_p = 30$ pF)	14 bits
Remaining offset	$< 15 \times 10^{-3}$ pF

Table 8. Specifications of the C12 mode.

The remaining offset capacitance is caused by the parasitics between bonding wires, bonding pads and IC pins. When this offset is too large, one should use the mode CMUX. In this case, an external multiplexer is used and offset can be as low as 20×10^{-6} pF.

8.4 Mode 3. CMUX: capacitors 0-2pF/0-12pF, external MUX

In this mode, an arbitrary number of capacitors in the range of 0 - 2 pF (CML = 0) or the range of 0 - 12 pF (CML = 1) with a common electrode can be measured. The UTI does not perform a phase selection, so an external multiplexer should be used. Just for this application, Smartec developed a novel multiplexer MUX with nine outputs and four inputs. The specifications of the CMUX mode are listed in Table 9.

Parameter	Typical value	Typical value
-----------	---------------	---------------

	(CML = 0)	(CML = 1)
K_1	10 $\mu\text{s/pF}$	1.7 $\mu\text{s/pF}$
C_0	2 pF	12 pF
Maximum capacitance C_{iA}	2 pF	12 pF
Linearity ($C_p < 300$ pF)	13 bits	13 bits
Offset	2×10^{-5} pF	2×10^{-5} pF
Resolution (SF = 0, $C_p < 30$ pF)	14 bits	14 bits

Table 9. Specifications of the CMUX mode.

A possible measurement setup is shown in Figure 7. An external multiplexer, which is controlled by the microcontroller (μC), multiplexes the signal at node B to one (or more) of the capacitors. The UTI output appears on the node "output". Nominal frequencies of the output signal during an offset measurement (none of the capacitors are selected) are 6 kHz (SF = 1) and 50 Hz (SF = 0).

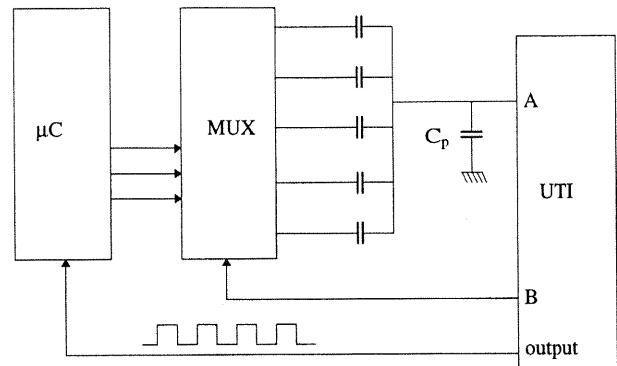

Figure 7. Possible measurement setup in the CMUX mode to measure multiple capacitors.

8.5 Mode 4. C300: 3 capacitors, range up to 300pF

In this mode, 3 capacitors in a variable range up to 300 pF with a common electrode can be measured. The connection of sensors and external resistors is depicted in Figure 8. These resistors set the voltage swing at the transmitting electrode of C_{iA} .

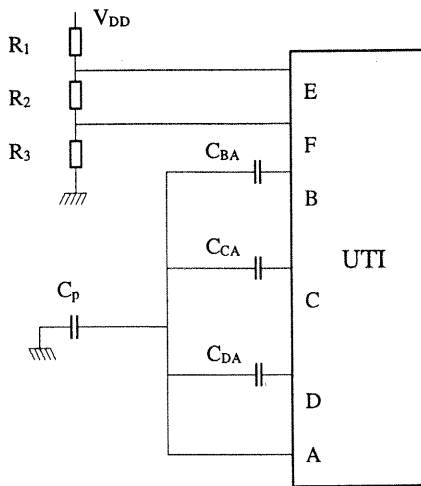

Figure 8. Connection of sensors to the UTI for the C300 mode.

The total capacitance at node A must be limited to 500 pF in order to keep the nonlinearity below 10^{-3} . The voltage swing at the transmitting electrodes equals V_{EF} which is set externally by means of three inaccurate resistors R_1 , R_2 and R_3 , of which R_1 or R_3 may be zero. The DC voltage V_{EF} should satisfy the following condition:

$$V_{EF} < K_V / C_{max}$$

where the constant $K_V = 60 \text{ V}\cdot\text{pF}$, and C_{max} is the maximum value of C_{BA} , C_{CA} and C_{DA} expressed in pF.

The total time constant of all resistors and capacitors should be less than 500 ns. This sets the values of the resistors.

Example. When $C_{CA} = 300 \text{ pF}$, $C_{DA} = 200 \text{ pF}$, $C_{BA} = 0$ and $V_{DD} = 5 \text{ V}$, practical values of the resistors are $R_1 = 25 \text{ k}\Omega$, $R_2 = 1 \text{ k}\Omega$ and $R_3 = 0$. The voltage swing V_{EF} at the transmitting electrode amounts to 0.2 V.

The system contains two time constants $C_{tot} \cdot (R_3 / (R_1 + R_2))$ and $C_{tot} \cdot (R_1 / (R_2 + R_3))$, where $C_{tot} = C_{BA} + C_{CA} + C_{DA} + C_p$. Both time constants must be smaller than 500 ns.

The nonlinearity and resolution in the slow mode are depicted in Table 10. Here, the value of $C_{DA} = 0 \text{ pF}$, $C_p = 30 \text{ pF}$ and V_{EF} has the maximum value K_V / C_{max} , as described before. The measured capacitors during each phase are listed in Table 11.

Capacitors	Nonlinearity	Resolution (pF)
$C_{BA}=C_{CA}=33 \text{ pF}$	1.4×10^{-4}	1.2×10^{-3}
$C_{BA}=C_{CA}=150 \text{ pF}$	1.9×10^{-4}	6.6×10^{-3}
$C_{BA}=C_{CA}=270 \text{ pF}$	9.0×10^{-4}	17×10^{-3}
$C_{BA}=C_{CA}=330 \text{ pF}$	2.6×10^{-3}	20×10^{-3}
$C_{BA}=C_{CA}=560 \text{ pF}$	6.3×10^{-3}	46×10^{-3}

Table 10. Values of nonlinearity and resolution in C300 mode for different capacitor values.

Phase	Capacitor	Output periods
1	$C_{BA} + C_0$	$T_{BA} = NK_1(C_{BA} + C_0)$
2	$C_{CA} + C_0$	$T_{CA} = NK_1(C_{CA} + C_0)$
3	$C_{DA} + C_0$	$T_{DA} = NK_1(C_{DA} + C_0)$

Table 11. The measured capacitors during each phase of the mode C300.

8.6 Mode 5. Pt: 1 platinum resistor Pt100/ Pt1000, 4-wire

In this mode, one platinum resistor and one reference resistor can be measured.

The connection of the resistors to the UTI is depicted in Figure 9. Because of the use of force/sense wires, both resistors R_x and R_{ref} are measured in a 4-wire setup, thereby completely eliminating the effect of lead resistances. The driving voltage V_{EF} is a square wave with amplitude V_{DD} at 1/4 of the internal oscillator frequency. Resistors R_{BIAS1} and R_{BIAS2} are used to set the current through the chain. When these two resistor values are equal, due to the symmetry, the highest accuracy is achieved. When one of these two resistors is zero, this will not affect the linearity, however, the accuracy will be decreased. For instance, for a measurement of a Pt100, this inaccuracy amounts to $\pm 40 \text{ m}\Omega$.

One measurement cycle consists of 4 phases. These phases contain the information for a 2-, 3- or 4-wire measurement.

Phase	Measured voltages	Output periods
1	V_0	$T_{off} = NK_2 V_0$
2	$V_{AB} + V_0$	$T_{AB} = NK_2 (V_{AB} + V_0)$
3	$V_{CD} + V_0$	$T_{CD} = NK_2 (V_{CD} + V_0)$
4	$V_{BC} + V_0$	$T_{BC} = NK_2 (V_{BC} + V_0)$

Table 12. Measured voltages during the measurement of platinum resistors

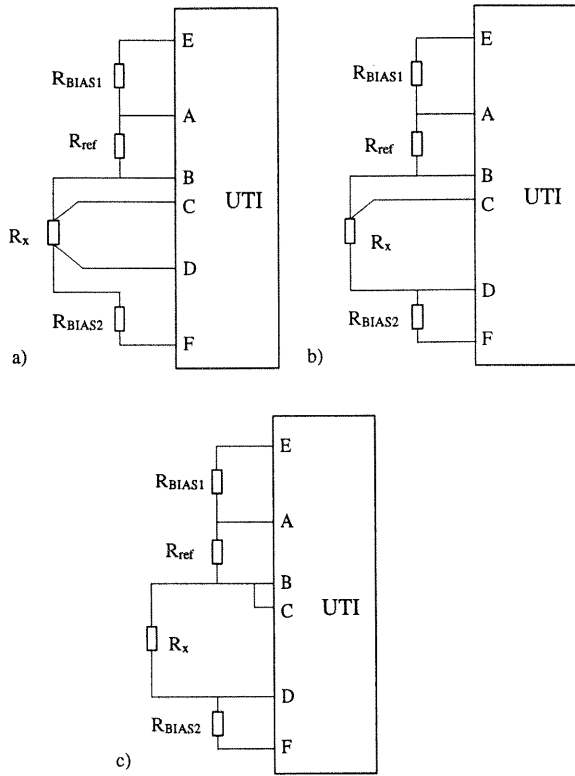

Figure 9. Connection of platinum resistors to the UTI in a 4-wire (a), 3-wire (b) and a 2-wire (c) connection.

To calculate the ratio as in (4), we have to make different calculations for the 2-, 3- and 4 wire measurement:

$$M_{2-,4-wire} = \frac{T_{phase3} - T_{phase1}}{T_{phase2} - T_{phase1}} = \frac{R_x}{R_{ref}} \quad (6)$$

$$M_{3-wire} = \frac{T_{phase3} - T_{phase4}}{T_{phase2} - T_{phase1}} = \frac{R_x}{R_{ref}}$$

The linearity is better than 13 bits provided that the amplitude of the voltages V_{AB} and V_{CD} is below 0.7 V for $V_{DD} = 5V$. For $V_{DD} = 3.3 V$, these voltages should be less than 0.4 V. This limits the current through the platinum resistor.

Current limitation is also required to limit the error due to self-heating. For instance, for a thermal resistance of 200 K/W (still air) at $V_{CD} = 0.7 V$ and $0^\circ C$, the self-heating effect of a Pt100 causes an error of 1 K. If this self-heating error is too large, R_{BIAS} ($= R_{BIAS1} + R_{BIAS2}$) must be increased to limit the current through the Pt100. For $V_{CD} = 0.2 V$, the temperature error due to self-heating would amount to 80 mK. This is two times less than the initial inaccuracy of a class A Pt100. In this case, the current through the Pt100 amounts to 2 mA which requires $R_{BIAS} = R_{BIAS1} + R_{BIAS2} = 2.2 k\Omega$.

The relative sensitivity of a Pt100 is $3.9 \times 10^{-3} / K$. When the current through the Pt100 is 2 mA, this sensitivity corresponds to 780 $\mu V / K$. The resolution in this mode is 7 μV , corresponding to 9 mK. This holds for the slow mode.

Table 13 lists the specifications of the UTI in the Pt mode.

Parameter ($V_{DD} = 5 V$)	Typical value
K_2	56 $\mu s / V$
V_0	0.36 V
R_{BIAS} (Pt100, self-heating for 200K/W = 80 mK)	2.2 k Ω (5%), $I = 2$ mA
R_{BIAS} (Pt1000, self-heating for 200K/W = 80 mK)	6.2 k Ω (5%), $I = 600 \mu A$
Excitation current from E and F	20 mA
Offset	10 μV
Linearity	13 bits
Resolution (SF = 0) (Pt100, 2 mA)	14 bits (9 mK)

Table 13. Specifications of the Pt mode.

Amplitudes of V_{CD} and V_{AB} up to 2.5 V peak-to-peak are allowed, but self-heating effects and nonlinearity have to be taken into account. Very good resolutions can be obtained in this case.

However, the linearity can decrease to 8 bits for peak-to-peak amplitudes in the range of 0.7-2.5 V.

Platinum resistors can also be measured using mode 11.

8.7 Mode 6. Ther: 1 thermistor, 4-wire

In this mode, one thermistor and one reference resistor can be measured. The connection of the thermistor and the reference resistor is shown in Figure 10.

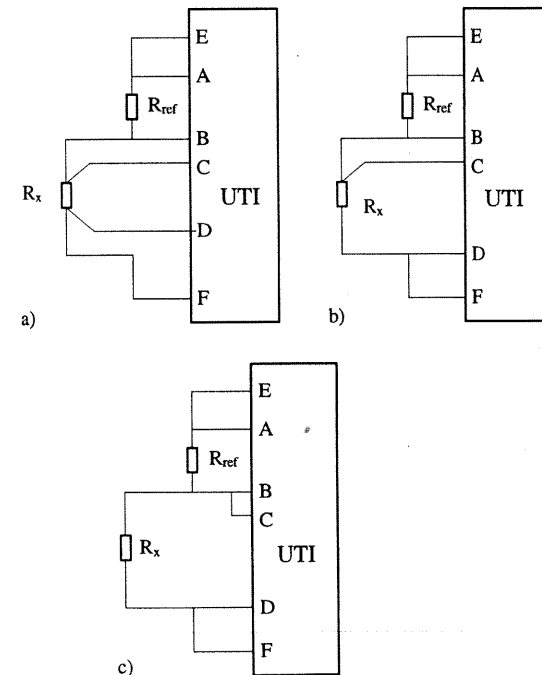

Figure 10. Connection of the thermistor to the UTI in a 4-wire (a), 3-wire (b) and 2-wire (c) connection.

The driving voltage V_{EF} is a chopped voltage with an amplitude of $V_{DD}/12.5$ (0.4 V at $V_{DD} = 5 V$) and a DC value $V_{DD}/2$.

The ratio of the thermistor and the reference resistor is also given by (6). The signals, which are measured

during the various phases, are listed in Table 12. The voltage V_{AB} is not constant, but has the same temperature information as V_{CD} , which linearises the sensor characteristic.

Parameter ($V_{DD} = 5\text{ V}$)	Typical value
K_2	56 $\mu\text{s/V}$
V_0	0.36 V
R_{ref}/R_x	<5 k Ω
$R_{ref}+R_x$	>1 k Ω
Offset	10 μV
Linearity	13 bits
Resolution (SF = 0)	7 μV (1 mK)

Table 14. Specifications of the Ther mode.

For very large and very small values of R_x (10 times or 0.1 times R_{ref}), the resolution in voltage is still the same, but the resolution in temperature is decreased. This is due to the linearization method.

For a thermistor with a sensitivity of 4%/K, the resolution is 1 mK for $V_{DD} = 5\text{ V}$.

8.8 Mode 7. Pt2: 2 or 3 platinum resistors

In this mode, 2 or 3 platinum resistors can be measured. The connection of the resistors to the UTI is shown in Figure 11. The voltage V_{EF} is the same as in the mode Pt.

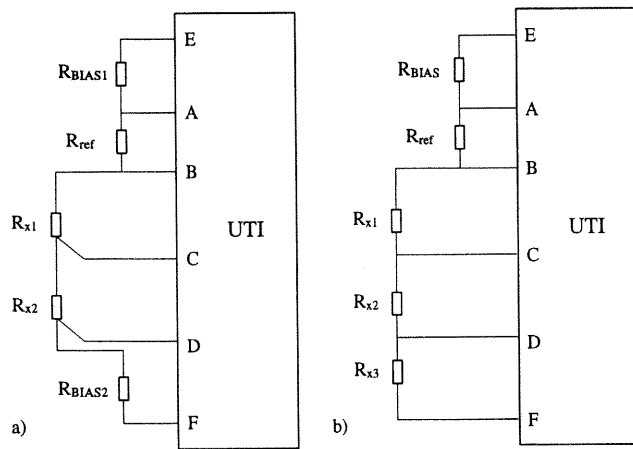

Figure 11. Connection of 2 (a) or 3 (b) platinum resistors for the Pt2 mode.

The same restrictions for the current through the resistors as in the Pt mode holds here. The specifications are listed in Table 13. Note that R_{x2} can be measured with a 4-wire setup. Phase 5 can be used to measure just one lead resistance or to measure R_{x3} .

The main difference with the Pt mode is that one measurement cycle takes 5 phases, as listed in Table 15.

Phase	Measured voltages	Output periods
1	V_0	$T_{off} = NK_2 V_0$
2	$V_{AB}+V_0$	$T_{AB} = NK_2 (V_{AB} + V_0)$
3	$V_{CD}+V_0$	$T_{CD} = NK_2 (V_{CD} + V_0)$
4	$V_{BC}+V_0$	$T_{BC} = NK_2 (V_{BC} + V_0)$
5	$V_{DF}+V_0$	$T_{DF} = NK_2 (V_{DF} + V_0)$

Table 15. Measured voltages during the phases of the Pt2 mode.

In the Figure 11(a), one of two bias resistors R_{BIAS1} and R_{BIAS2} can be zero. However, in this case the accuracy will be decreased. With the connection shown in Figure 11(b), the effect of lead resistances can not be eliminated. Especially, when R_{x3} is measured with the connection shown in Figure 11(b), the internal connection wires of the UTI will cause an error of 0.9 Ω for the Pt100 and 3 Ω for the Pt1000, respectively. This measured error depends on the supply current of the platinum resistors, and temperature.

8.9 Mode 8. Ther2: 2 or 3 thermistors

In this mode, 2 or 3 thermistors can be measured. The connection is depicted in Figure 12. The number of phases is also 5, as listed in Table 15. The specifications listed in Table 14 also hold for this mode.

With the connection shown in Figure 12(b), the effect of lead resistances can not be eliminated. Especially, when R_{x3} is measured with the connection shown in Figure 12(b), the internal connection wires of the UTI will cause an error of 11.5 Ω for the resistor R_{x3} with a value of 2.5 k Ω . This measured error depends on the supply current of the thermistor, and temperature.

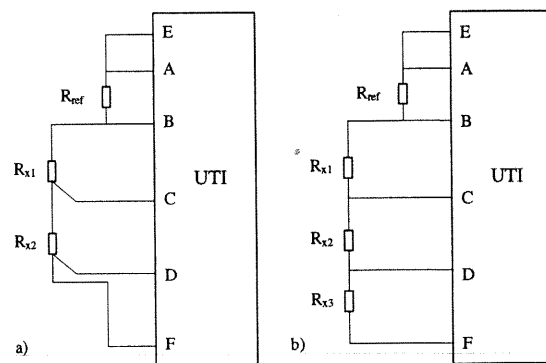

Figure 12. Connections of 2 (a) and 3 (b) thermistors to the UTI.

8.10 Mode 9. Ub2: resistive bridge, ref. is V_{bridge} , +/- 4% imbalance

In this mode, a resistive bridge can be measured where the ratio of the bridge output voltage V_{CD} and the bridge supply voltage V_{AB} represents the physical signal.

The measurement range of the bridge imbalance is +/- 4% in this mode.

The connection of the bridge to the UTI is shown in Figure 13. The driving voltage across the bridge V_{EF} is a square wave with amplitude V_{DD} . The frequency of this signal is 1/4 of the internal oscillator frequency.

Because of the use of force/sense wires, the bridge is measured in a 4-wire setup, as shown in Figure 13(a). The signals measured in the various phases are indicated in Table 16.

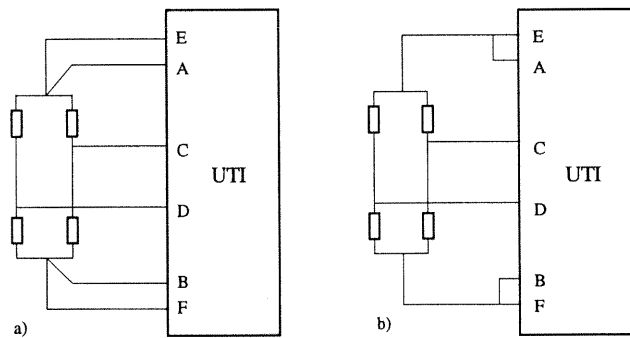

Figure 13. Connection of the resistive bridge to the UTI for the Ub2 mode in a 4-wire setup (a) and a 2-wire setup (b).

During phase 2, the voltage across the bridge V_{AB} is measured. A very accurate on-chip voltage divider divides this voltage by 32. This divider does not need calibration. After division, V_{AB} is processed in the same way as V_{CD} .

Phase	Measured voltages	Output periods
1	V_0	$T_{\text{off}} = NK_2 V_0$
2	$V_{AB}/32 + V_0$	$T_{AB} = NK_2 (V_{AB} / 32 + V_0)$
3	$V_{CD} + V_0$	$T_{CD} = NK_2 (V_{CD} + V_0)$

Table 16. Measurement phases of the Ub2 mode.

To find the bridge imbalance, the microcontroller calculates:

$$M = \frac{1}{32} \frac{T_{\text{phase3}} - T_{\text{phase1}}}{T_{\text{phase2}} - T_{\text{phase1}}} = \frac{V_{CD}}{V_{AB}} \quad (7)$$

The specifications are listed in Table 17.

Parameter	Typical value
K_2	56 $\mu\text{s/V}$
V_0	0.54 V
Bridge excitation	AC V_{DD}
Excitation current from E and F	20 mA
Bridge resistance R_b	$250 \Omega < R_b < 10 \text{ k}\Omega$
Bridge output voltage	max +/- 0.2V
Accuracy	11 bits
Offset	10 μV
Resolution (SF = 0)	7 μV

Table 17. Specifications of the Ub2 mode.

8.11 Mode 10. Ub1: res. bridge, ref. is V_{bridge} , +/- 0.25% imbalance

In this mode, a resistive bridge can be measured where the ratio of the bridge output voltage and the bridge supply voltage represents the physical signal.

The main difference with mode Ub2 is that the measurement range of the bridge imbalance is 0.25%. ($V_{CD} = 12.5 \text{ mV}$ for $V_{DD} = 5\text{V}$).

The connection of the bridge to the UTI is the same as in the Ub2 mode. An on-chip 15-times voltage amplifier amplifies the small output voltage before it is processed in the same way as the divided voltage across the bridge. Both the amplifier and divider do not need calibration. To calculate the bridge imbalance, Equation (7) can be used, where 32 must be replaced by 480. Due to the use of the force/sense wires, the bridge is measured in a 4-wire setup.

The various voltages measured during each phase are indicated in Table 18. The specifications are listed in Table 19.

Phase	Measured voltages	Output periods
1	V_0	$T_{\text{off}} = NK_2 V_0$
2	$V_{AB}/32 + V_0$	$T_{AB} = NK_2 (V_{AB} / 32 + V_0)$
3	$15V_{CD} + V_0$	$T_{CD} = NK_2 (15 \cdot V_{CD} + V_0)$

Table 18. Measured voltages during each phase of the Ub1 mode.

Parameter	Typical value
K_2	56 $\mu\text{s/V}$
V_0	0.54 V
Bridge excitation	AC V_{DD}
Excitation current from E and F	20 mA
Bridge resistance R_b	$250 \Omega < R_b < 10 \text{ k}\Omega$
Bridge output voltage	max +/- 12.5 mV
Accuracy	10 bits
Offset	10 μV
Resolution (SF = 0)	700 nV

Table 19. Specifications of the Ub1 mode.

8.12 Mode 11. Ib2: resistive bridge, ref. is I_{bridge} , +/- 4% imbalance

In this mode, a resistive bridge can be measured where the physical signal is represented by the output voltage of the bridge and the current through the bridge. This current I is converted into a reference voltage. The connection of the bridge and the reference element is shown in Figure 14(a).

The value of R_{ref} should be chosen such that V_{AB} is between 0.1 V and 0.2 V.

This mode can also be used to measure platinum resistors in a 4-wire setup. This is shown in Figure 14(b). The advantage in comparison with mode Pt is that now only three phases have to be measured.

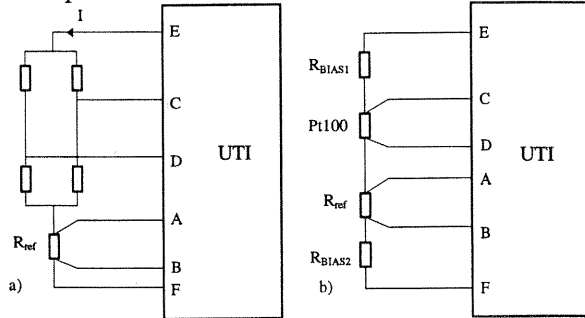

Figure 14. Connection of the resistive bridge and a reference resistor to the UTI (a) and connection of a platinum resistor in 4-wire setup (b).

Phase	Measured voltages	Output periods
1	V_0	$T_{off} = NK_2 V_0$
2	$V_{AB} + V_0$	$T_{AB} = NK_2 (V_{AB} + V_0)$
3	$V_{CD} + V_0$	$T_{CD} = NK_2 (V_{CD} + V_0)$

Table 20. Measured voltages for each phase of the Ib2 mode.

Parameter	Typical value
K_2	56 $\mu\text{s/V}$
V_0	0.54 V
Bridge excitation	AC V_{DD}
Excitation current from E and F	20 mA
Bridge resistance R_b	$250 \Omega < R_b < 10 \text{ k}\Omega$
Bridge output voltage	max +/- 0.2 V
Accuracy	12 bits
Offset	10 μV
Resolution (SF=0)	7 μV

Table 21. Specifications of the Ib2 mode.

8.13 Mode 12. Ib1: resistive bridge, ref. is I_{bridge} , +/- 0.25% imbalance

This mode is similar to mode 11. The connection of the bridge and the resistor is shown in Figure 14.

The difference with mode 11 is that the bridge imbalance range is +/- 0.25%. The voltage across the

reference resistor should be between 0.1 V and 0.2 V, as in mode 11.

The bridge output voltage is amplified 15 times before it is processed in the same way as the reference voltage.

The voltages measured during each phase are indicated in Table 22. The specifications of the Ib1 mode are listed in Table 23.

Phase	Measured voltages	Output periods
1	V_0	$T_{off} = NK_2 V_0$
2	$V_{AB} + V_0$	$T_{AB} = NK_2 (V_{AB} + V_0)$
3	$15V_{CD} + V_0$	$T_{CD} = NK_2 (15V_{CD} + V_0)$

Table 22. Measured voltages during each phase of the Ib1 mode.

To find the bridge imbalance, the microcontroller calculates

$$M = \frac{1}{15} \frac{T_{phase3} - T_{phase1}}{T_{phase2} - T_{phase1}} = \frac{V_{CD}}{I R_{ref}} \quad (8)$$

Parameter	Typical value
K_2	56 $\mu\text{s/V}$
V_0	0.54 V
Bridge excitation	AC V_{DD}
Excitation current from E and F	20 mA
Bridge resistance R_b	$250 \Omega < R_b < 10 \text{ k}\Omega$
Bridge output voltage	max +/- 12.5 mV
Accuracy	10 bits
Offset	10 μV
Resolution (SF = 0)	700 nV

Table 23. Specifications of the Ib1 mode.

8.14 Mode 13. Brg2: resistive bridge +/- 4% and 2 resistors

In this mode, a resistive bridge with a maximum imbalance of +/-4% and two resistors can be measured. One of the resistors can be temperature dependent, so the bridge output can be digitally corrected for temperature effects.

Both the voltage across the bridge and the current through the bridge are measured. The connection of the elements to the UTI is shown in Figure 15.

The voltage V_{EF} is a square wave with an amplitude V_{DD} at 1/4 of the oscillator frequency. The voltage across R_{ref} should be between 0.1 V and 0.2V.

The voltages to be measured are indicated in Table 24.

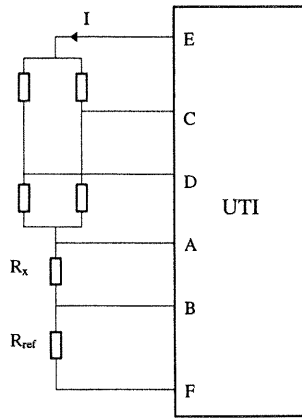

Figure 15. Connections of the sensors to the UTI.

Phase	Measured voltages	Output periods
1	V_0	$T_{off} = NK_2 V_0$
2	$V_{AB} + V_0$	$T_{AB} = NK_2 (V_{AB} + V_0)$
3	$V_{CD} + V_0$	$T_{CD} = NK_2 (V_{CD} + V_0)$
4	$V_{BF} + V_0$	$T_{BF} = NK_2 (V_{BF} + V_0)$
5	$V_{EA}/32 + V_0$	$T_{EA} = NK_2 (V_{EA} / 32 + V_0)$

Table 24. Signals during the various phases of the mode Brg2.

The voltage across the bridge V_{EA} is divided by 32 before it is processed in the same way as the other measured voltages. The bridge imbalance V_{CD}/V_{EA} is obtained from:

$$M = \frac{1}{32} \frac{T_{phase3} - T_{phase1}}{T_{phase5} - T_{phase1}} = \frac{V_{CD}}{V_{EA}} \quad (9)$$

The specifications of this mode are listed in Table 25.

Parameter	Typical value
K_2	56 $\mu\text{s}/\text{V}$
V_0	0.54 V
Excitation V_{EF}	AC V_{DD}
Excitation current from E and F	20 mA
Bridge resistance R_b	$250 \Omega < R_b < 10 \text{ k}\Omega$
Bridge output voltage	max +/- 0.2 V
Accuracy V_{CD}/V_{EA}	11 bits
Linearity V_{AB}/V_{BF}	12 bits
Offset V_{CD} or V_{AB}	10 μV
Resolution (SF = 0)	7 μV

Table 25. Specifications of the Brg2 mode.

For the measurement of the signal V_{BF} , due to the effect of the internal connection wires of the UTI, an error of 1.2% will be caused on the result of V_{AB}/V_{BF} . This measured error depends on the supply current of the resistive bridge and temperature.

8.15 Mode 14. Brg1: resistive bridge +/- 0.25% and 2 resistors

This mode is similar to mode 13. The connection is shown in Figure 15. The difference with mode 13 is that the measurement range of the bridge imbalance is 0.25%. The bridge output voltage V_{CD} is amplified 15 times before it is processed further.

The voltages measured during each phase are indicated in Table 26. The specifications are listed in Table 27.

Phase	Measured voltages	Output periods
1	V_0	$T_{off} = NK_2 V_0$
2	$V_{AB} + V_0$	$T_{AB} = NK_2 (V_{AB} + V_0)$
3	$15V_{CD} + V_0$	$T_{CD} = NK_2 (15V_{CD} + V_0)$
4	$V_{BF} + V_0$	$T_{BF} = NK_2 (V_{BF} + V_0)$
5	$V_{EA}/32 + V_0$	$T_{EA} = NK_2 (V_{EA} / 32 + V_0)$

Table 26. Measured voltages during each phase of the Brg1 mode.

Parameter	Typical value
K_2	56 $\mu\text{s}/\text{V}$
V_0	0.54 V
Excitation V_{EF}	AC V_{DD}
Excitation current from E and F	20 mA
Bridge resistance R_b	$250 \Omega < R_b < 10 \text{ k}\Omega$
Bridge output voltage	max +/- 12.5 mV
Accuracy V_{CD}/V_{EA}	10 bits
Linearity V_{AB}/V_{BF}	12 bits
Offset V_{CD}	10 μV
Offset V_{AB}	10 μV
Resolution V_{CD} (SF = 0)	700 nV
Resolution V_{AB} (SF = 0)	7 μV

Table 27. Specifications of the mode Brg1.

For the measurement of the signal V_{BF} , due to the effect of the internal connection wires of the UTI, an error of 1.2% will be caused on the result of V_{AB}/V_{BF} . This measured error depends on the supply current of the resistive bridge and temperature.

8.16 Mode 15. Potm: 3 potentiometers, 1k Ω -25k Ω

In this mode, 3 potentiometers in the range of 1 k Ω to 50 k Ω can be measured. The connection of potentiometers is depicted in Figure 16. When only a single potentiometer is measured with its slide connected to, for instance, node B, nodes C and D should be connected to F. The voltage across the potentiometers is a square wave with amplitude V_{DD} and frequency 1/4 of the internal oscillator frequency.

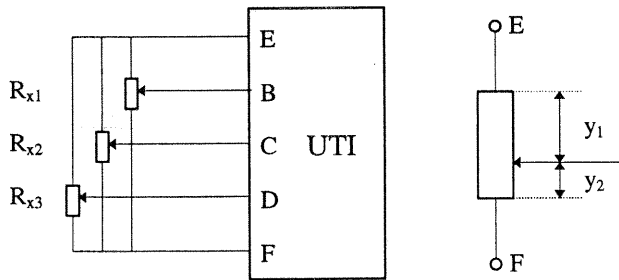

Figure 16. Connection of potentiometers to the UTI.

It is not possible to compensate for the effect of lead wires in this mode. Therefore, the use of low-ohmic potentiometers should be avoided.

The measured voltages during each phase are indicated in Table 28.

Phase	Measured Voltages	Output periods
1	V_0	$T_{off} = NK_2 V_0$
2	$V_{EF} + V_0$	$T_{EF} = NK_2 (V_{EF} + V_0)$
3	$V_{CF} + V_0$	$T_{CF} = NK_2 (V_{CF} + V_0)$
4	$V_{BF} + V_0$	$T_{BF} = NK_2 (V_{BF} + V_0)$
5	$V_{DF} + V_0$	$T_{DF} = NK_2 (V_{DF} + V_0)$

Table 28. Measured voltages for each phase during measurement of potentiometers.

The relative position M for each potentiometer is given by:

$$M = \frac{T_{phase3,4,5} - T_{phase1}}{T_{phase2} - T_{phase1}} = \frac{y_2}{y_1 + y_2} \quad (10)$$

Parameter	Typical value
K_2	$4 \mu s/V$
V_0	5 V
Potentiometer value R_{xi}	$1 k\Omega < R_{xi} < 25 k\Omega$
Accuracy	10^{-3}
Resolution (SF = 0)	14 bits

Table 29. Specifications of the Potm mode.

9. Chip Size

Figure 17 shows the pad configuration of the UTI chip. The size of the die amounts to $3.1 \text{ mm} \times 2.1 \text{ mm}$.

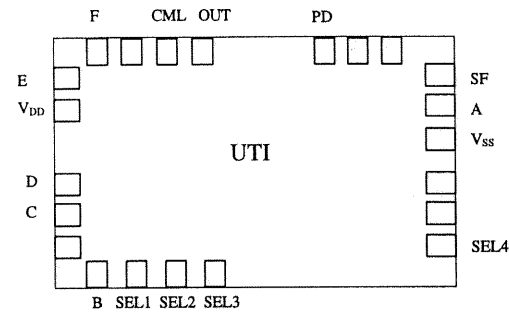

Figure 17 The pad configuration of UTI chip.

10. Development Kit

For actual development purposes, a development kit is available. This kit can be connected directly to a personal computer. Additional practical information can be found in the UTI application note.