

**Product Preview**

**VOICE ACTIVATED SWITCH**

The MC2830 circuit incorporates a microphone amplifier (MIC AMP), automatic level control (ALC) and a voice activated switch. The voice activated switch circuit has the ability to distinguish a voice from the background noise and trigger the switch output circuit by the voice signal. Therefore, the switching operation is highly reliable in noisy environments. The ALC range of the microphone amplifier is over 50 dB and can be adjusted by an external resistor. This device is particularly suitable for applications such as radio transceivers, car radios, message storage recorders, and voice controlled toys.

- Microphone Amplifier with External Feedback
- External Resistor Adjust ALC Over 50 dB
- Voice Activated Switch with Externally Controlled Sensitivity
- Low Voltage Operation from 1.8 to 8.0 V

**MC2830**

**VOICE ACTIVATED SWITCH**

**SILICON MONOLITHIC INTEGRATED CIRCUIT**

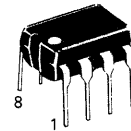

**P SUFFIX**  
 PLASTIC PACKAGE  
 CASE 626



**D SUFFIX**  
 PLASTIC PACKAGE  
 CASE 751  
 (SO-8)

**FIGURE 1 — FUNCTIONAL BLOCK DIAGRAM**

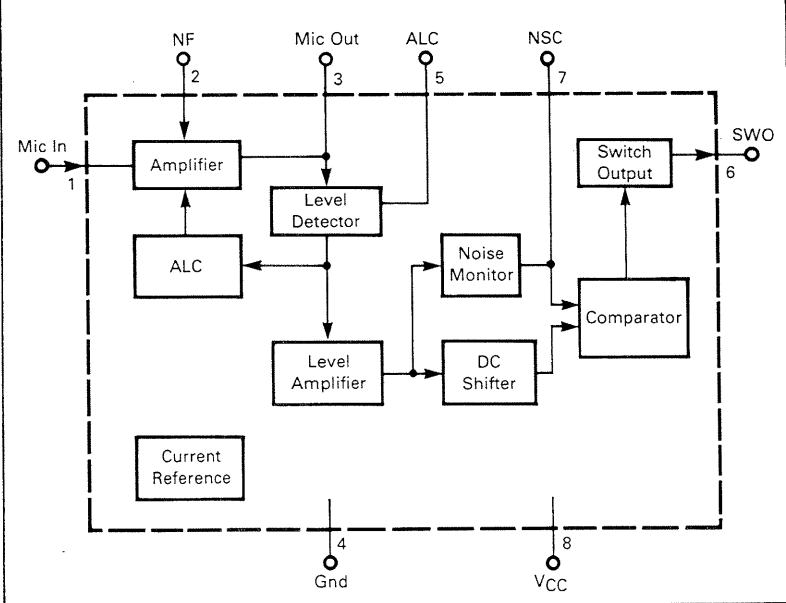

**PIN CONNECTIONS**

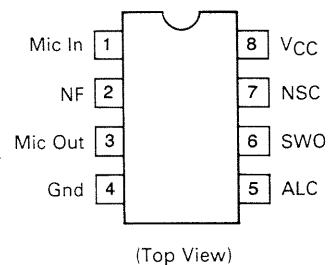

**ORDERING INFORMATION**

Device	Temperature Range	Package
MC2830D	0 to +70°C	SO-8
MC2830P		Plastic DIP

This document contains information on a product under development. Motorola reserves the right to change or discontinue this product without notice.

# MC2830

## MAXIMUM RATINGS

Rating	Symbol	Value	Unit
Supply Voltage	$V_{CC}$	10	V
Operation Temperature Range	$T_A$	0 to +70	°C
Storage Temperature Range	$T_{stg}$	-65 to +150	°C
Loading Current: Pin 3	$I_O$	200	$\mu A$
Pin 6	$I_{SWO}$	2.0	mA

## ELECTRICAL CHARACTERISTICS ( $V_{CC} = 5.0$ V, Input Frequency = 1.0 kHz, Loading Resistor = 50 kOhm, $T_A = 25^\circ C$ )

Characteristic	Pin	Symbol	Min	Typ	Max	Unit
Supply Voltage	8	$V_{CC}$	1.8	—	8.0	V
Quiescent Current	8	$I_D$	—	—	2.0	mA
MIC AMP Open Loop Gain		$A_{VOL}$	—	80	—	dB
Total Harmonic Distortion of MIC AMP ( $V_O = 0.1$ Vrms)	3	THD	—	1.0	—	%
Maximum MIC AMP Output Swing	3	$V_O$	—	0.16	—	Vrms
ALC Range (-6.0 dB, $R_1 = 33$ k, $V_{in} = 1.0$ V)	3	ALC	40	50	—	dB
Ripple Rejection	3	RR	—	55	—	dB
Voice Trigger Level Above Noise		$V_{S/n}$	—	3.0	—	dB
Switch Output Current	6	$I_{SWO}$	—	—	2.0	mA
Switch Output Voltage ( $I_{SWO} = 2.0$ mA) High Low	6	$V_{SWO}$	4.6 —	— —	— 0.4	V

## PIN FUNCTION DESCRIPTION

Pin No.	Function	Description
1	MIC IN	Input of the microphone amplifier. The gain of the amplifier is set by the external components of the $R_f$ , $R_2$ , and $C_2$ (See formula 2).
2	NF	This is the negative feedback input pin of the microphone amplifier.
3	MIC OUT	Output of the microphone amplifier. It is designed to drive a maximum load current of 200 $\mu A$ .
4	GND	The ground pin.
5	ALC	This pin is for the ALC level detector filter. An RC is connected to this pin.
6	SWO	This is the output pin of the voice activated switch. A resistor at this pin sets the voice trigger level above the noise level. The current drain of this pin is around 20 $\mu A$ typical with a switch "off" state. The maximum output voltage level is $V_{CC} - V_{CES}$ with a maximum output current of 2.0 mA. As shown in Figure 3, this output is used to connect a switch time delay circuit to unify the "on" time. In Figure 3, $C_5$ is the time delay capacitor which controls the "on" time of TR1.
7	NSC	The Noise Storing Capacitor at this pin sets the rise time and decay time. The rise time is determined by the constant of the $R_5C_4$ .
8	$V_{CC}$	This pin has a low voltage operation from 1.8 to 8.0 Volts.

# MC2830

FIGURE 2 — TEST CIRCUIT

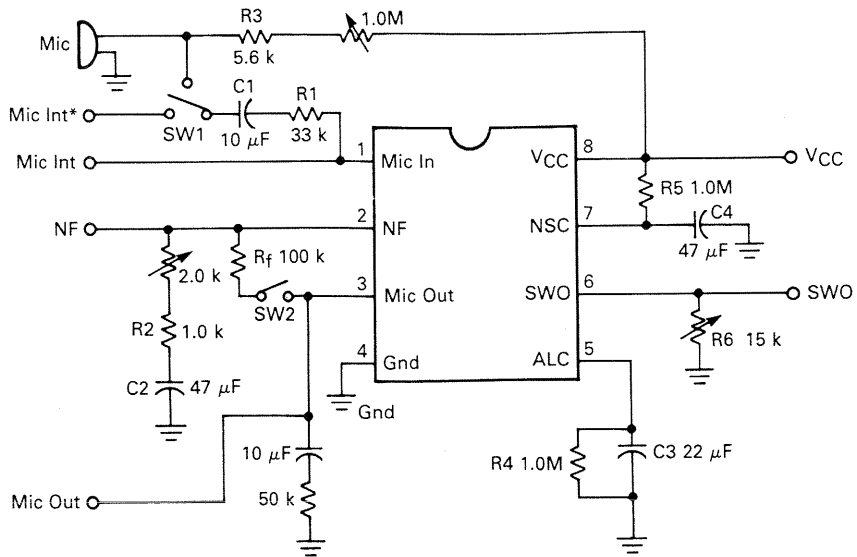
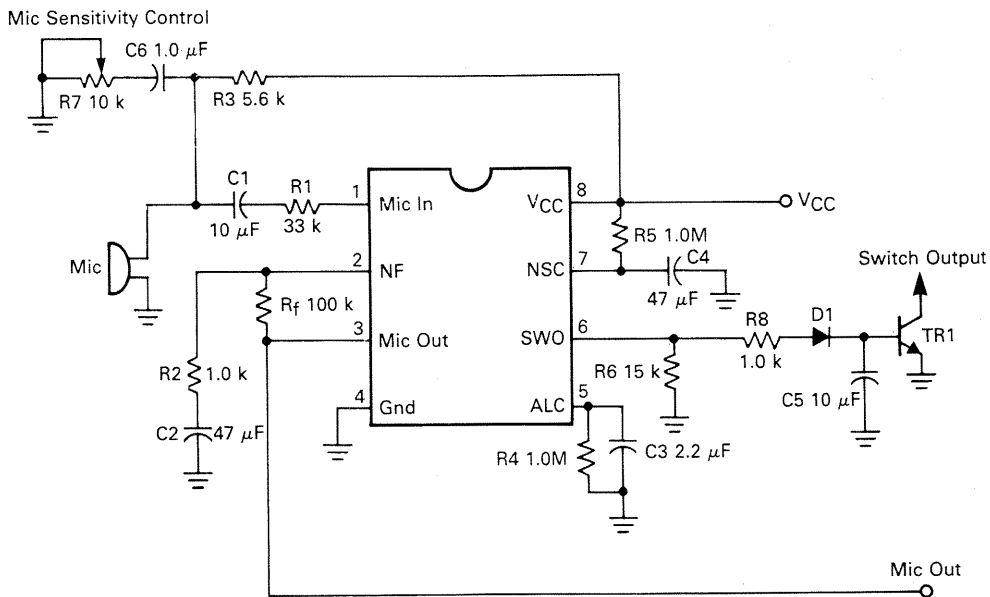

FIGURE 3 — TYPICAL APPLICATION CIRCUIT



# MC2830

## FUNCTIONAL DESCRIPTION

As shown in the block diagram, the features provided by the MC2830 are the microphone amplifier with ALC and voice switch circuit. The detailed functional circuitry is described below.

### Microphone Amplifier

The MIC AMP is a noninverting amplifier as shown in Figure 4. An ALC controlled resistance is connected to the input pin of the MIC AMP to accomplish ALC function. The voltage gain and ALC attenuation ratio are given in formulas (1) and (2):

$$\text{Voltage Gain} = 1 + \frac{R_f}{R_2 = 1/\omega C_2} \quad (1)$$

$$\text{ALC} = 20 \log \left( \frac{R_1 + R_{alc}}{R_{alc}} \right) \quad (2)$$

Replacing  $R_f$  by a  $Z_f$  network can be formed as a band pass, low pass or high pass network for various applications.

FIGURE 4 — MIC AMPLIFIER WITH ALC

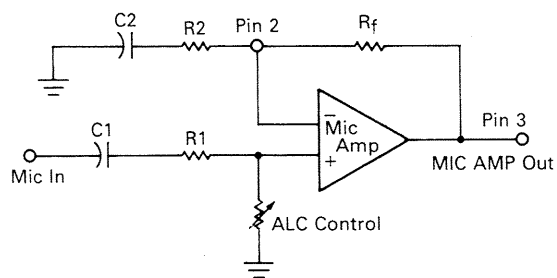

A typical application circuit is shown in Figure 3, the ALC performance of the microphone amplifier is shown in Figure 5.

FIGURE 5 — ALC CHARACTERISTICS

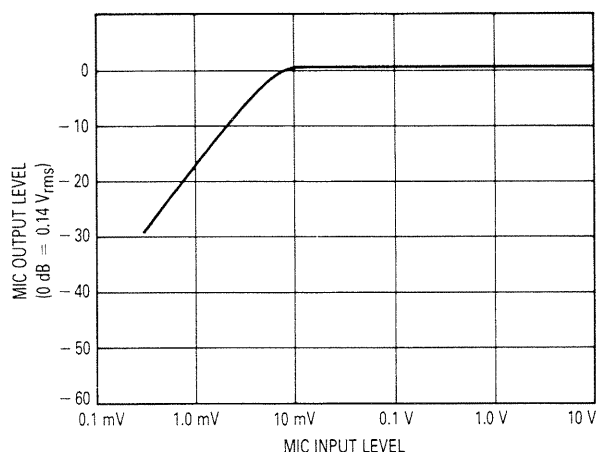

### Voice Detection and Switching

A traditional voice activated circuit design is unable to distinguish between voice and noise in the incoming signal. In a noisy environment, the switch is often mis-triggered by noise, or the activation sensitivity must be reduced. The MC2830 voice activated circuit has overcome this weakness in traditional designs. The switch is activated by voice level above the noise and is not affected by the background noise level. This is accomplished by utilizing the differences in voice and noise waveforms. Voice waveforms generally have a wide range of variation in amplitude, whereas noise waveforms are more stable. With this in mind, the NOISE MONITOR in Figure 1 was designed to have an output characteristic which has a slow attack time but a fast decay time. When the envelope of incoming signal, which consists of voice and noise, is passing through it, the voice will not be stable during the long time constant of RC (approx. 45 seconds) and it is therefore degraded. Whereas the noise content of incoming signal is delayed at the rising edge of its envelope, as in Figure 6. Meanwhile, the envelope of the incoming signal is passing through the DC SHIFTER path, which does not introduce any time constant or amplification, but gives the incoming signal envelope a dc offset set by resistor R6.

By comparing the two signals from the output of the DC SHIFTER and the NOISE MONITOR, as in Figure 6, the voice is distinguished from the incoming signal and activates the switch circuit. The sensitivity of voice activation depends on the value of R6. The voice activation sensitivity is reduced from 3.0 dB to 8.0 dB above the noise if R6 changes from 14 k to 7.0 k.

FIGURE 6 — WAVEFORMS OF VOICE DETECTION AND SWITCHING

