

# HD74HC155

## Dual 2-to-4-line Decoders/Demultiplexers

# HITACHI

### Description

This circuit features dual 1-line-to-4-line demultiplexer with individual strobes and common binary-address input. When both sections are enabled by the strobes, the common binary-address inputs sequentially select and route associated input data to the appropriate output of each section. The individual strobes permit activating or inhibiting each of the 4-bit sections as desired. Data applied to input 1C is inverted through its outputs. The inverter following the 1C data input permits use as a 3-to-8-line decoder or 1-to-8-line demultiplexer without external gating.

### Features

- High Speed Operation:  $t_{pd}$  (A or B to Y) = 15 ns typ ( $C_L = 50$  pF)
- High Output Current: Fanout of 10 LSTTL Loads
- Wide Operating Voltage:  $V_{CC} = 2$  to 6 V
- Low Input Current: 1  $\mu$ A max
- Low Quiescent Supply Current:  $I_{CC}$  (static) = 4  $\mu$ A max ( $T_a = 25^\circ\text{C}$ )

### Function Table

#### 2-line-to-4-line Decoder/1-line-to-4-line Demultiplexer

##### Inputs

Select		Strobe	Data	Outputs			
B	A	1G	1C	1Y <sub>0</sub>	1Y <sub>1</sub>	1Y <sub>2</sub>	1Y <sub>3</sub>
X	X	H	X	H	H	H	H
L	L	L	H	L	H	H	H
L	H	L	H	H	L	H	H
H	L	L	H	H	H	L	H
H	H	L	H	H	H	H	L
X	X	X	L	H	H	H	H

# HD74HC155

## Inputs

Select		Strobe	Data	Outputs			
B	A	2G	2C	2Y <sub>0</sub>	2Y <sub>1</sub>	2Y <sub>2</sub>	2Y <sub>3</sub>
X	X	H	X	H	H	H	H
L	L	L	L	L	H	H	H
L	H	L	L	H	L	H	H
H	L	L	L	H	H	L	H
H	H	L	L	H	H	H	L
X	X	X	H	H	H	H	H

## 3-line-to-8-line Decoder/1-line-to-8-line Demultiplexer

Inputs				Outputs							
Select		Strobe Data		0	1	2	3	4	5	6	7
C	B	A	G	2Y <sub>0</sub>	2Y <sub>1</sub>	2Y <sub>2</sub>	2Y <sub>3</sub>	1Y <sub>0</sub>	1Y <sub>1</sub>	1Y <sub>2</sub>	1Y <sub>3</sub>
X	X	X	H	H	H	H	H	H	H	H	H
L	L	L	L	L	H	H	H	H	H	H	H
L	L	H	L	H	L	H	H	H	H	H	H
L	H	L	L	H	H	L	H	H	H	H	H
L	H	H	L	H	H	H	L	H	H	H	H
H	L	L	L	H	H	H	H	L	H	H	H
H	L	H	L	H	H	H	H	H	L	H	H
H	H	L	L	H	H	H	H	H	H	L	H
H	H	H	L	H	H	H	H	H	H	H	L

- Notes:
1. C: inputs 1C and 2C connected together
  2. G: inputs 1G and 2G connected together
  3. X: irrelevant

Pin Arrangement

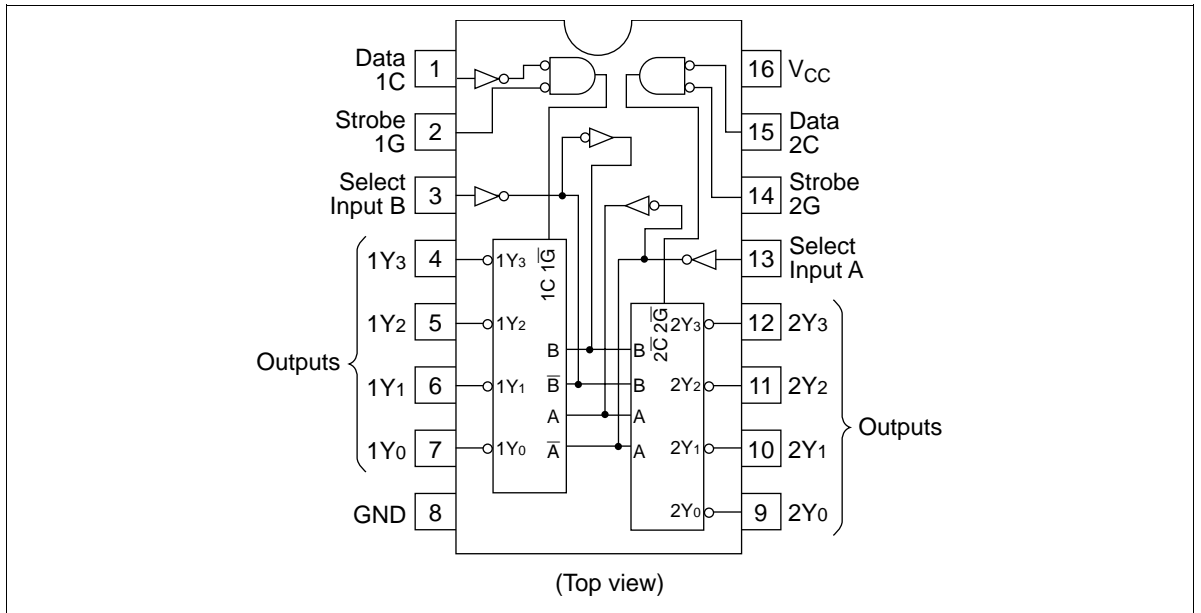

## DC Characteristics

Item	Symbol	V <sub>CC</sub> (V)	Ta = 25°C			Ta = -40 to +85°C		Unit	Test Conditions	
			Min	Typ	Max	Min	Max			
Input voltage	V <sub>IH</sub>	2.0	1.5	—	—	1.5	—	V		
		4.5	3.15	—	—	3.15	—			
		6.0	4.2	—	—	4.2	—			
	V <sub>IL</sub>	2.0	—	—	0.5	—	0.5			V
		4.5	—	—	1.35	—	1.35			
		6.0	—	—	1.8	—	1.8			
Output voltage	V <sub>OH</sub>	2.0	1.9	2.0	—	1.9	—	V	Vin = V <sub>IH</sub> or V <sub>IL</sub> I <sub>OH</sub> = -20 μA	
		4.5	4.4	4.5	—	4.4	—			
		6.0	5.9	6.0	—	5.9	—			
		4.5	4.18	—	—	4.13	—			I <sub>OH</sub> = -4 mA
		6.0	5.68	—	—	5.63	—			I <sub>OH</sub> = -5.2 mA
		6.0	—	0.0	0.1	—	0.1			V
	4.5	—	0.0	0.1	—	0.1				
	6.0	—	0.0	0.1	—	0.1				
	4.5	—	—	0.26	—	0.33	I <sub>OL</sub> = 4 mA			
	6.0	—	—	0.26	—	0.33	I <sub>OL</sub> = 5.2 mA			
Input current	I <sub>in</sub>	6.0	—	—	±0.1	—	±1.0	μA	Vin = V <sub>CC</sub> or GND	
Quiescent supply current	I <sub>CC</sub>	6.0	—	—	4.0	—	40	μA	Vin = V <sub>CC</sub> or GND, I <sub>out</sub> = 0 μA	

AC Characteristics ( $C_L = 50 \text{ pF}$ , Input  $t_r = t_f = 6 \text{ ns}$ )

Item	Symbol	$V_{CC}$ (V)	Ta = 25°C		Ta = -40 to +85°C		Unit	Test Conditions	
			Min	Typ	Max	Min			Max
Propagation delay time	$t_{PLH}$	2.0	—	—	160	—	200	ns	A, B, 2C, 1G or 2G to Y
		4.5	—	13	32	—	40		
		6.0	—	—	27	—	34		
	$t_{PHL}$	2.0	—	—	160	—	200	ns	A or B to Y
			4.5	—	15	32	—		
		6.0	—	—	27	—	34		1C to Y
			2.0	—	—	145	—		
		4.5	—	14	29	—	36		
			6.0	—	—	25	—		31
Output rise/fall time	$t_{TLH}$	2.0	—	—	75	—	95	ns	
	$t_{THL}$	4.5	—	5	15	—	19		
		6.0	—	—	13	—	16		
Input capacitance	$C_{in}$	—	—	5	10	—	10	pF	



Hitachi Code	DP-16
JEDEC	Conforms
EIAJ	Conforms
Weight (reference value)	1.07 g



\*Dimension including the plating thickness  
Base material dimension

Hitachi Code	FP-16DA
JEDEC	—
EIAJ	Conforms
Weight (reference value)	0.24 g



\*Dimension including the plating thickness  
Base material dimension

Hitachi Code	FP-16DN
JEDEC	Conforms
EIAJ	Conforms
Weight (reference value)	0.15 g