

HD74HC51

2-wide 2-input, 2-wide 3-input AND-OR-INVERT Gate

HITACHI

Features

- High Speed Operation: $t_{pd} = 10.5$ ns typ ($C_L = 50$ pF)
- High Output Current: Fanout of 10 LSTTL Loads
- Wide Operating Voltage: $V_{CC} = 2$ to 6 V
- Low Input Current: 1 μ A max
- Low Quiescent Supply Current: I_{CC} (static) = 1 μ A max ($T_a = 25^\circ\text{C}$)

Pin Arrangement

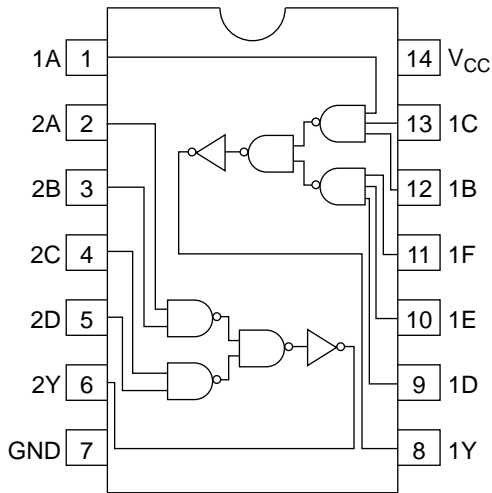

(Top view)

HD74HC51

DC Characteristics

Item	Symbol	V _{CC} (V)	Ta = 25°C		Ta = -40 to +85°C		Unit	Test Conditions	
			Min	Typ	Max	Min			Max
Input voltage	V _{IH}	2.0	1.5	—	—	1.5	—	V	
		4.5	3.15	—	—	3.15	—		
		6.0	4.2	—	—	4.2	—		
	V _{IL}	2.0	—	—	0.5	—	0.5		V
		4.5	—	—	1.35	—	1.35		
		6.0	—	—	1.8	—	1.8		
Output voltage	V _{OH}	2.0	1.9	2.0	—	1.9	—	Vin = V _{IH} or V _{IL} I _{OH} = -20 μA	
		4.5	4.4	4.5	—	4.4	—		
		6.0	5.9	6.0	—	5.9	—		
		4.5	4.18	—	—	4.13	—		I _{OH} = -4 mA
		6.0	5.68	—	—	5.63	—		I _{OH} = -5.2 mA
	V _{OL}	2.0	—	0.0	0.1	—	0.1	Vin = V _{IH} or V _{IL} I _{OL} = 20 μA	
		4.5	—	0.0	0.1	—	0.1		
		6.0	—	0.0	0.1	—	0.1		
		4.5	—	—	0.26	—	0.33		I _{OL} = 4 mA
		6.0	—	—	0.26	—	0.33		I _{OL} = 5.2 mA
Input current	I _{in}	6.0	—	—	±0.1	—	±1.0	μA	Vin = V _{CC} or GND
Quiescent supply current	I _{CC}	6.0	—	—	1.0	—	10	μA	Vin = V _{CC} or GND, I _{out} = 0 μA

AC Characteristics ($C_L = 50$ pF, Input $t_r = t_f = 6$ ns)

Item	Symbol	V_{CC} (V)	Ta = 25°C		Ta = -40 to +85°C		Unit	Test Conditions
			Min	Typ	Max	Min		
Propagation delay time	t_{PLH}	2.0	—	—	110	—	140	ns
		4.5	—	11	22	—	28	
		6.0	—	—	19	—	24	
	t_{PHL}	2.0	—	—	110	—	140	
		4.5	—	10	22	—	28	
		6.0	—	—	19	—	24	
Output rise time	t_{TLH}	2.0	—	—	75	—	95	
		4.5	—	5	15	—	19	
		6.0	—	—	13	—	16	
Output fall time	t_{THL}	2.0	—	—	75	—	95	
		4.5	—	5	15	—	19	
		6.0	—	—	13	—	16	
Input capacitance	C_{in}	—	—	5	10	—	10	pF

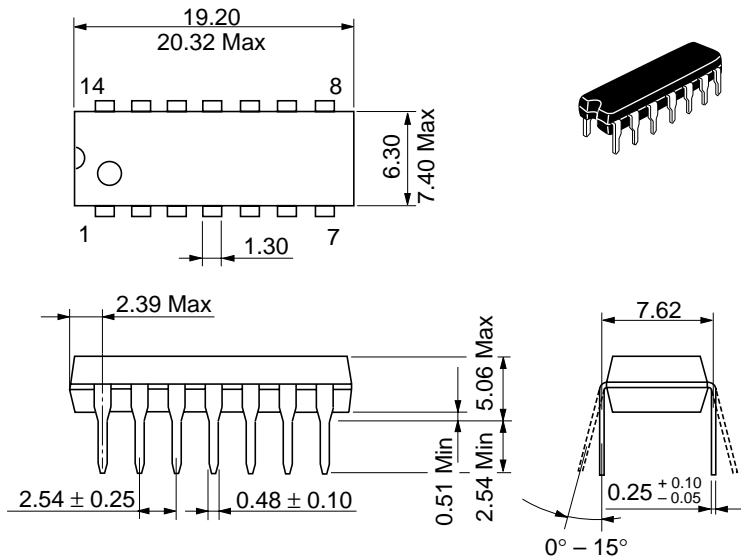

Hitachi Code	DP-14
JEDEC	Conforms
EIAJ	Conforms
Weight (reference value)	0.97 g

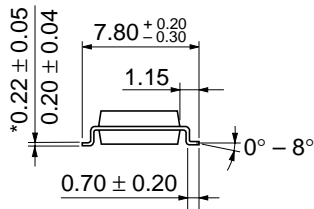

Hitachi Code	FP-14DA
JEDEC	—
EIAJ	Conforms
Weight (reference value)	0.23 g

*Dimension including the plating thickness
Base material dimension



Hitachi Code	FP-14DN
JEDEC	Conforms
EIAJ	Conforms
Weight (reference value)	0.13 g

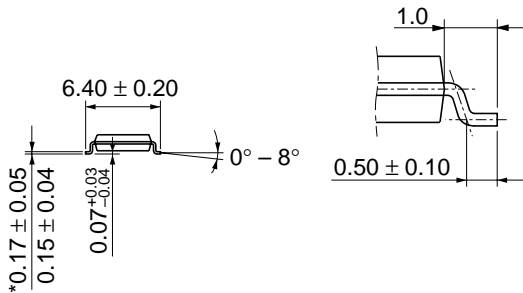
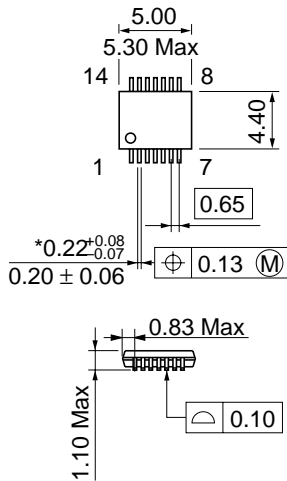

*Dimension including the plating thickness
 Base material dimension

Hitachi Code	TTP-14D
JEDEC	—
EIAJ	—
Weight (reference value)	0.05 g