



2 MBIT PCM SIGNALLING CIRCUIT MJ 1440 HDB3 ENCODER/DECODER

The 2.048 MBit PCM Signalling Circuits comprise a group of circuits which will perform the common signalling and error detection functions for a 2.048 MBit PCM transmission link operating to the appropriate CCITT recommendations. The circuits are fabricated in N-channel metal gate MOS and operate from a single 5 volt supply, relevant inputs and outputs are TTL compatible.

The MJ1440 is an encoder/decoder for the pseudo-ternary transmission code, HDB3 (CCITT Orange Book Vol III.2 Annex to Rec. G703). The device encodes and decodes simultaneously and asynchronously. Error monitoring functions are provided to detect violations of HDB3 coding, all ones detection and loss of input (all zeroes detection). In addition a loop back function is provided for terminal testing.

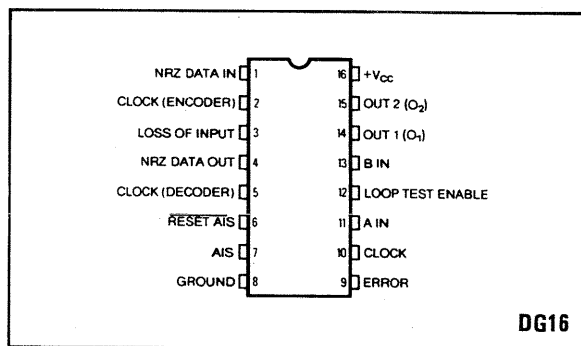

Fig. 1 Pin connections

FEATURES

- 5v ± 5% Supply - 50mA Max
- HDB3 Encoding and Decoding to CCITT rec. G703.
- Asynchronous Operation.
- Simultaneous Encoding and Decoding.
- Clock Recovery Signal Generated from Incoming HDB3 Data.
- Loop Back Control.
- HDB3 Error Monitor
- 'All Ones' Error Monitor
- Loss of Input Alarm (All Zeros Detector).
- Decode Data in NRZ Form.

ABSOLUTE MAXIMUM RATINGS

The absolute maximum ratings are limiting values above which operating life may be shortened or specified parameters may be degraded.

Electrical Ratings

+Vcc	7V
Inputs	Vcc + 0.5V Gnd - 0.3V
Outputs	Vcc, Gnd - 0.3V

Thermal Ratings

Max Junction Temperature	175°C
Thermal Resistance: Chip to Case	40°C/Watt
Chip to Amb.	120°C/Watt

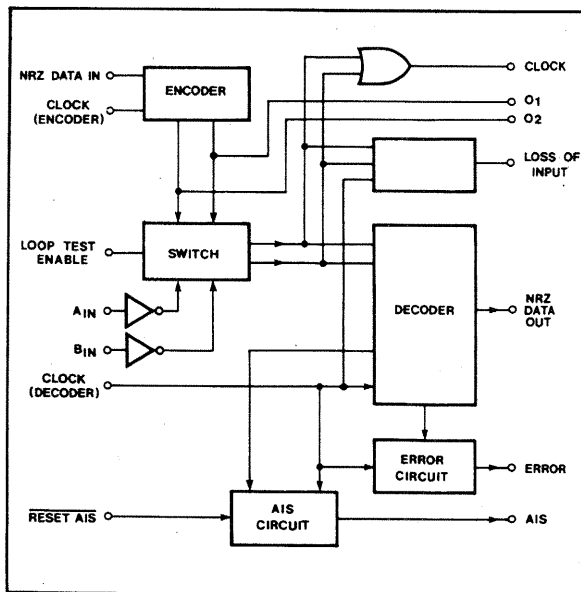

Fig. 2 Block diagram

MJ1440

ELECTRICAL CHARACTERISTICS

Test conditions (unless otherwise stated):

Supply voltage, $V_{CC} = 5V \pm 0.25V$

Ambient temperature, $T_{amb} = 0^{\circ}C$ to $+70^{\circ}C$

Static characteristics

Characteristic	Symbol	Pins	Value			Units	Conditions
			Min	Typ	Max		
Low level input voltage	V_{IL}	1,2,5,6 10,11,12,13	-0.3		0.8	V	$V_{IL} = 0V$
Low level input current	I_{IL}				50	μA	
High level input voltage	V_{IH}		2.5		V_{CC}	V	
High level input current	I_{IH}				50	μA	
Low level output voltage	V_{OL}	10,14,15			0.5	V	$I_{sink} = 80\mu A$ $I_{sink} = 1.6mA$
		3,4,7,9			0.4	V	
High level output voltage	V_{OH}	3,4,7,9	2.7			V	$I_{source} = 60\mu A$ $I_{source} = 2mA$ $I_{source} = 1mA$
		14,15	2.8			V	
Supply current	I_{CC}	10	2.8	20	50	mA	All inputs to 0V All outputs open circuit

Dynamic Characteristics

Characteristic	Symbol	Value			Units	Conditions
		Min.	Typ.	Max.		
Max. Clock (Encoder) frequency	$f_{max_{enc}}$	4.0	10		MHz	Figs.10, 15
Max. Clock (Decoder) frequency	$f_{max_{dec}}$	2.2	5		MHz	Figs.11, 15
Propagation delay Clock (Encoder) to O_1, O_2	$tpd1A/B$			100	ns	Figs.10, 15. See Note 1
Rise and Fall times O_1, O_2				20	ns	Figs.10, 15
$tpd1A-tpd1B$				20	ns	Figs.10, 15
Propagation delay Clock (Encoder) to Clock	$tpd3$			150	ns	Loop test enable = Figs.13, 15
Setup time of NRZ data in to Clock (Encoder)	$ts3$	30			ns	Figs.8, 10, 15
Hold time of NRZ data in	$th3$	55			ns	Figs.10, 15
Propagation delay A_{in}, B_{in} to Clock	$tpd2$			150	ns	Loop test enable = '0' Figs.9, 13, 15
Propagation delay Clock (Decoder) to loss of input				150	ns	
Propagation delay Clock (Decoder) to error	$tpd4$			200	ns	Figs.12, 15
Propagation delay $\overline{Reset AIS}$ to AIS	$tpd5$			200	ns	Loop test enable = '0' Figs.14, 15
Propagation delay Clock (Decoder) to NRZ data out	$tpd6$			150	ns	Figs.9, 11, 15. See Note 2
Setup time of A_{in}, B_{in} to Clock (Decoder)	$ts1$	75			ns	Figs.9, 11, 15
Hold time of A_{in}, B_{in} to Clock (Decoder)	$th1$	5			ns	Figs.9, 11, 15
Hold time of $\overline{Reset AIS} = '0'$	$th2$	30			ns	Figs.9, 14, 15
Setup time Clock (Decoder) to $\overline{Reset AIS}$	$ts2$	100			ns	Figs.9, 14, 15
Setup time $\overline{Reset AIS} = 1$ to Clock (Decoder)	$ts2'$	0			ns	Figs.14, 15

NOTES

1. Encoded HDB3 outputs (O_1, O_2) are delayed by $3\frac{1}{2}$ clock periods from NRZ data in (Fig.3)
2. The decoded NRZ output is delayed by 4 clock periods from the HDB3 inputs (A_{IN}, B_{IN}) (Fig.4)

FUNCTIONAL DESCRIPTION

Functions Listed by pin number

1. NRZ Data in

Input data for encoding into ternary HDB3 form. The NRZ data is clocked-by the negative edge of the Clock (Encoder).

2. Clock (Encoder)

Clock for encoding data on pin 1

3. Loss of input alarm

This output goes to logic '1' if eleven consecutive zeroes are detected in the incoming HDB3 data. The output is set to logic '0' on receipt of a '1'.

4. NRZ data out

Decoded data in NRZ form from ternary HDB3 input data (A_{in}, B_{in}), data is clocked out by positive going edge of clock (Decoder).

5. Clock (Decoder)

Clock for decoding ternary data A_{in}, B_{in} .

6, 7. Reset AIS, AIS

Logic '0' on Reset AIS resets a decoded zero counter and either resets AIS outputs to zero provided 3 or more zeroes have been decoded in the preceding Reset AIS = 1 period or sets AIS to '1' if less than 3 zeroes have been decoded in the preceding Reset AIS = 1 period.

Logic '1' on Reset AIS enables the internal decoded zero counter.

8. Ground

Zero volts

9. Error

A logic '1' indicates that a violation of the HDB3 coding has been received i.e. 3 '1's of the same polarity.

10. Clock

'OR' function of $\overline{A_{in}}, \overline{B_{in}}$ for clock regeneration when pin 12 = '0'. 'OR' function of O_1, O_2 when pin 12 = '1'.

11, 13. A_{in}, B_{in}

Inputs representing the received ternary HDB3 PCM signal. A_{in} = '0' represents a positive going '1', B_{in} = '0' represents a negative going '1'. A_{in} and B_{in} are sampled by the positive going edge of the Clock (Decoder). A_{in} and B_{in} may be interchanged.

12. Loop test enable

Input to select normal or loop back operation. Pin 12 = '0' selects normal operation, encode and decode are independent and asynchronous. When pin 12 = '1' O_1 is connected internally to A_{in} , O_2 is connected internally to B_{in} . Clock becomes the OR function $O_1 + O_2$. The delay from NRZ in to NRZ out is $7\frac{1}{2}$ clock periods in the loop back condition.

14, 15. O_1, O_2

Outputs representing the ternary encoded data for line transmission O_1 = '1' representing a positive going '1', O_2 = '1' represents a negative going '1'. O_1 and O_2 may be interchanged.

16. V_{cc}

Positive supply, $5V \pm 5\%$

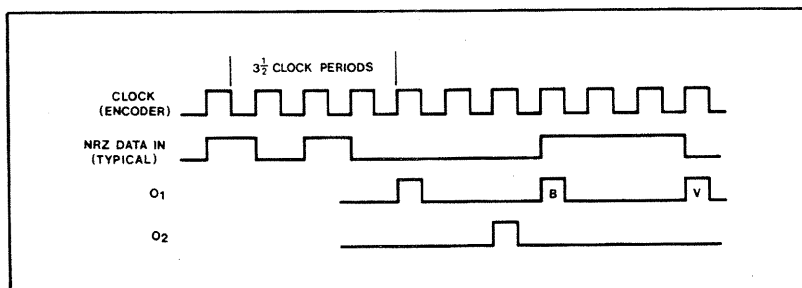

Fig. 3 Encode waveforms

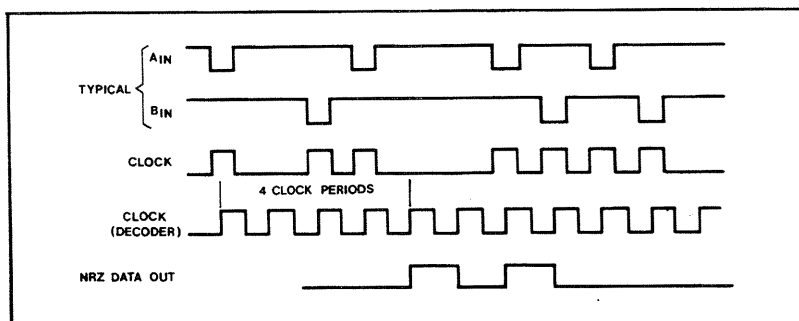

Fig. 4 Decode waveforms

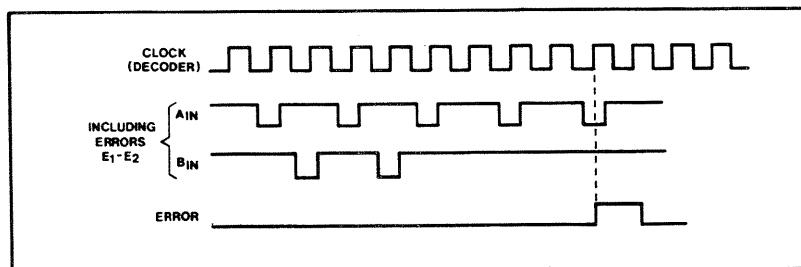

Fig. 5 HDB3 error output waveforms

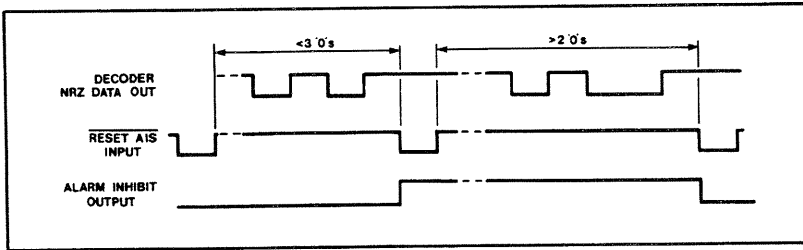

Fig. 6 AIS error and reset waveforms

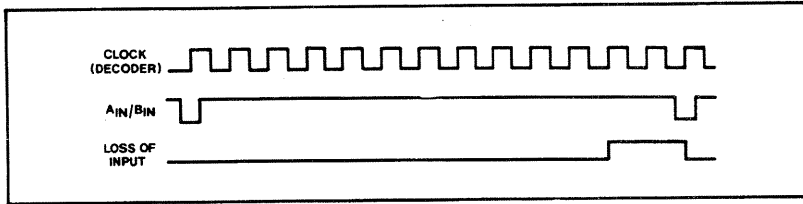

Fig. 7 Loss of input waveforms

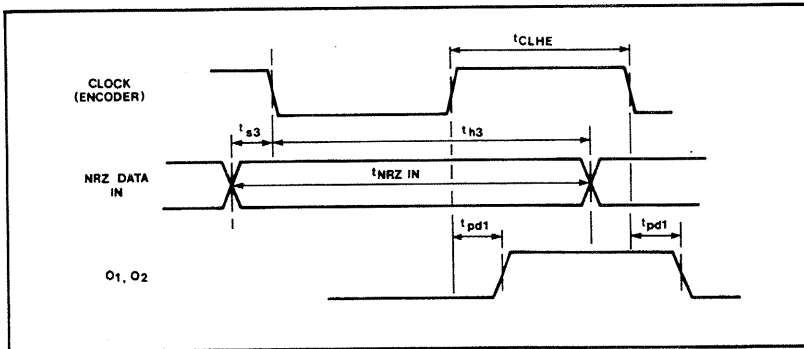

Fig. 8 Encoder timing relationship

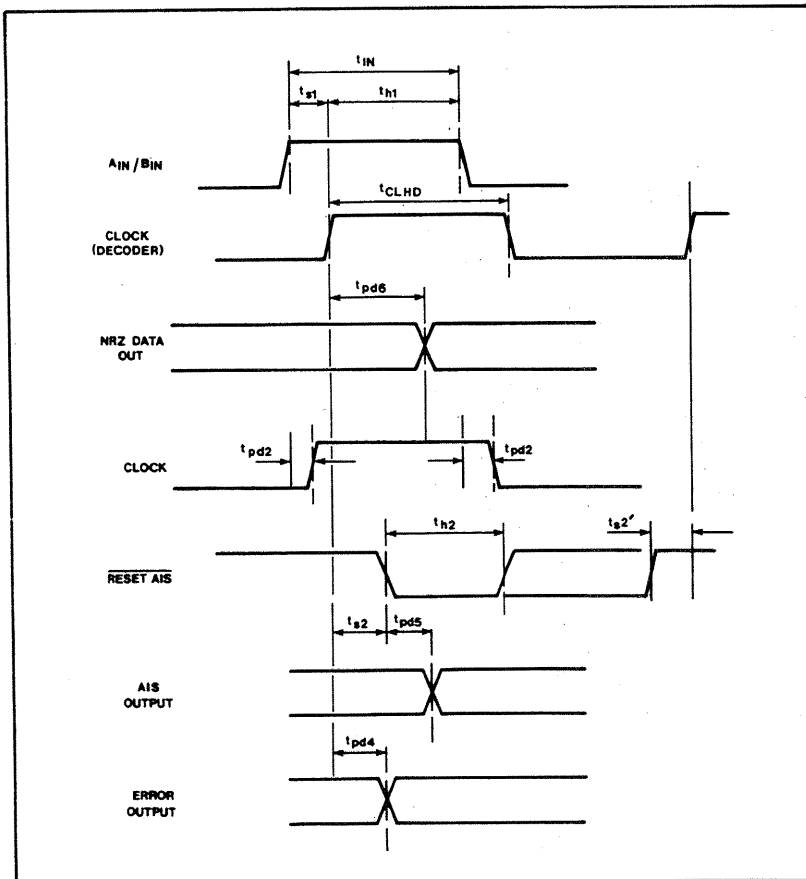

Fig. 9 Decoder timing relationship

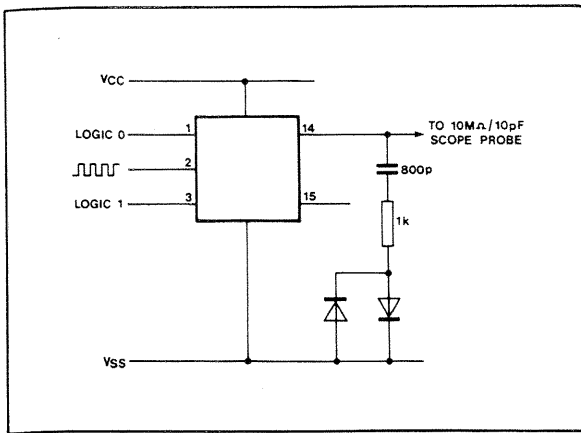

Fig. 10

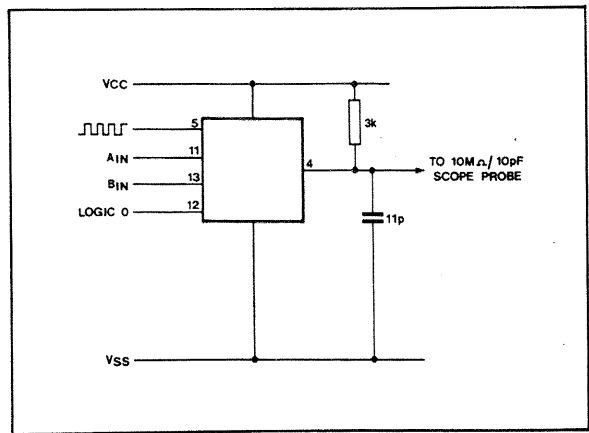

Fig. 11

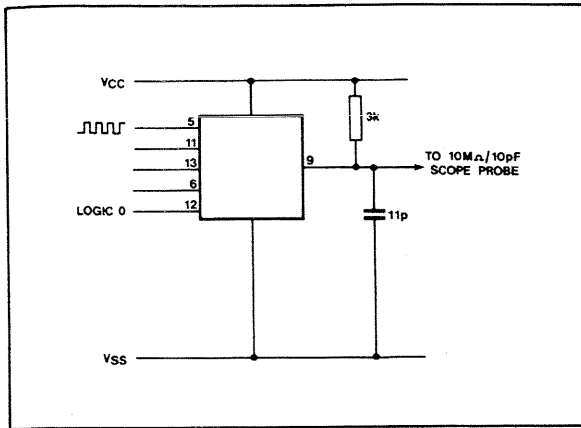

Fig. 12

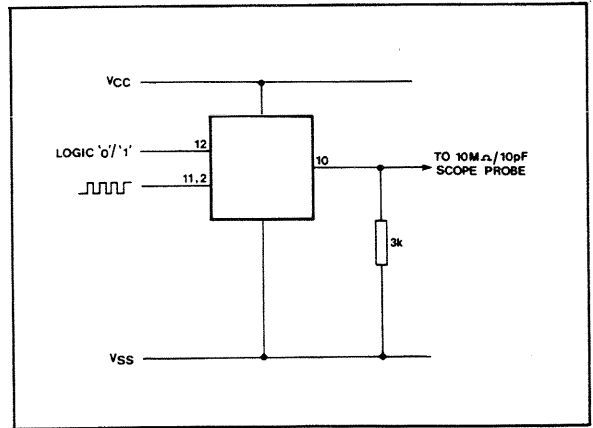

Fig. 13

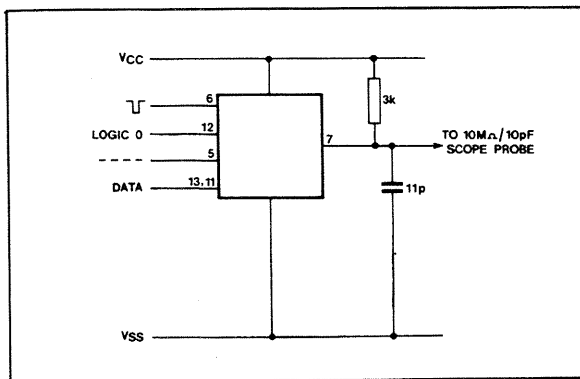

Fig. 14

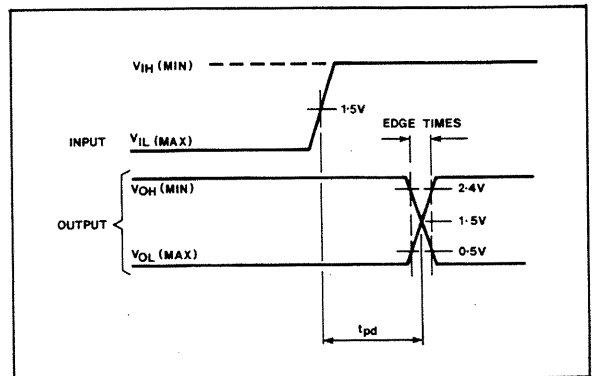

Fig. 15 Test timing definitions

DEFINITION OF THE HDB3 CODE

Coding of a binary signal into an HDB3 signal is done according to the following rules:

1. The HDB3 signal is pseudo-ternary; the three states are denoted B₊, B₋ and O.
2. Spaces in the binary signal are coded as spaces in the HDB3 signal. For strings of four spaces however, special rules apply (see 4. below).
3. Marks in the binary signal are coded alternately as B₊ and B₋ in the HDB3 signal (alternate mark inversion). Violations of the rule of alternate mark inversion are introduced when coding strings of four spaces (see 4. below).
4. Strings of four spaces in the binary signal are coded according to the following rules:
 - a The first space of a string is coded as a space if the

preceding mark of the HDB3 signal has a polarity opposite to the polarity of the preceding violation and is not a violation by itself; it is coded as a mark, i.e. not a violation (i.e. B₊, B₋), if the preceding mark of the HDB3 signal has the same polarity as that of the preceding violation or is by itself a violation.

This rule ensures that successive violations are of alternative polarity so that no DC component is introduced.

b The second and third spaces of a string are always coded as spaces.

c The last space of a string of four is always coded as a mark, the polarity of which is such that it violates the rule of alternate mark inversion. Such violations are denoted V₊ or V₋ according to their polarity.