

# LDT Series Elements with Lead Attachment and Lamination

The 'L' in LDT stands for 'laminated' sensor. Typically, a 0.005" (125µm) polyester layer is laminated to a 28 µm or 52µm piezo film element. When used in a 'bending' mode, laminated film elements develop much higher voltage output when flexed than a non-laminated DT elements series. The neutral axis is in the laminate instead of in the film so the film is strained more when flexed.

The capacitance is proportional to the area and inversely proportional to the thickness of the element.

Piezo film sensors LDT elements are available in a variety of lead attachment options. For significantly increased sensitivity, the LDTM-028K (M-Mass) combines an LDT0-028K form factor with the addition of a .72 gram round mass. The LDT1, 2 and 4 have 12" of 26 gauge twisted pair wire.

The LDT0-028K and LDTM-028K with solder tabs can be soldered directly to a PCB with a reasonable level of care. Piezo film cannot withstand high temperatures (>80°C), and therefore soldering of the pins to a PCB must be done quickly. A heatsink clamped to the interface area between the film and the crimps will take the heat away from the film. Pre-tin the PCB and then quickly solder the sensor to the board. Do not allow the soldering iron to touch the film, and do not use a dwell time of over 5 seconds on the pins. Low temperature solders can also be used.

Applications for this include beam-type vibration sensors for vehicle alarms and solid state

switches for counters and momentary closure type switches.

For tightly tolerance sensitivity requirements, please consult MSI Sensors for techniques used to control variations of boundary conditions in production.



(LDT Series with rivets & wire leads)

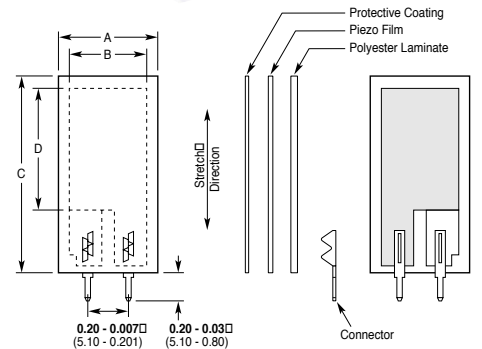
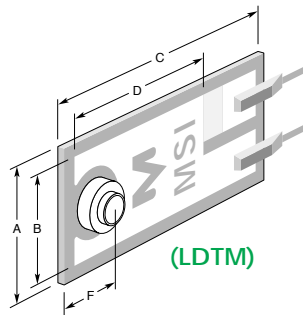
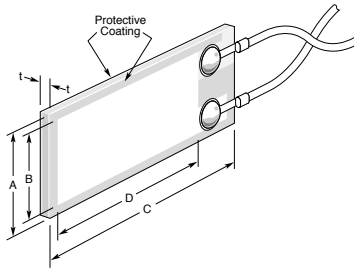

(LDT0-028K with crimped-on solder tabs)

## DIMENSIONS in INCHES (mm)

Description	A Film	B Electrode	C Film	D Electrode	t (µm)	Cap (nF)	Part Number	Low Volume Price (US \$)
LDT0-028K/L w/crimps	.520 (13)	.400 (10)	.980 (25)	.580 (15)	205	.500	0-1002794-0	\$.75
LDT0-025K/L w/crimps	.520 (13)	.400 (10)	.980 (25)	.580 (15)	205	.500	1-1004696-0	\$1.25
LDT1-028K/L w/rivets	.640 (16)	.484 (12)	1.63 (41)	1.19 (30)	205	1.38	0-1002910-0	\$2.50
LDT2-028K/L w/rivets	.640 (16)	.484 (12)	2.86 (73)	2.42(62)	205	2.78	0-1003745-0	\$4.50
LDT4-028K/L w/rivets	.860 (22)	.740 (19)	6.72 (171)	6.13 (156)	205	11.0	0-1002405-0	\$7.50
LDTM-028K/L w/crimps	.520 (13)	.400 (10)	.980 (25)	.580 (15)	205	.420	0-1005447-1	\$1.00

Please contact factory for custom part quotations and volume pricing.