



MERRY
ELECTRONICS
CO., LTD.

SPECIFICATIONS

TITLE
DYNAMIC MYLAR SPEAKER

MODEL NO.
DSH305 SC

PART NO.

SHEET
1
OF
2

1. MAGNET: Rare Earth Cobalt Magnet
2. IMPEDANCE: 100 ohm at 1KHz
3. IMPEDANCE TOLERANCE:
4. SENSITIVITY: 89 ± 4 dB 1mw at 1.5mm from standard microphone at 1KHz
in free field
5. FREOUENCY RESPONSE: Fo -18 KHz
6. RESONANCE (Fo): 150. ± 30 Hz
7. RATED INPUT: 10 mw
8. MAX INPUT: 30 mw
9. DIMENSION: 23 mmφ X 6 mmH

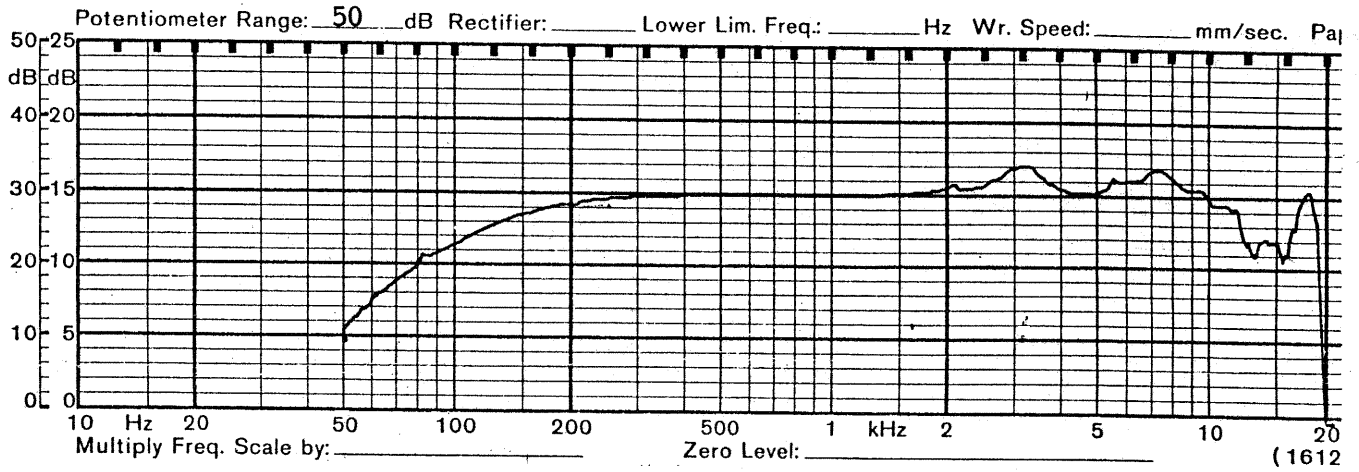

REV	ECO NO.	REMARK	DATE	BY
APPROVED BY	80 8 15	CHECK	80 8 15	DRAWING
		PROJ. ENG		

REV ECO NO DATE BY

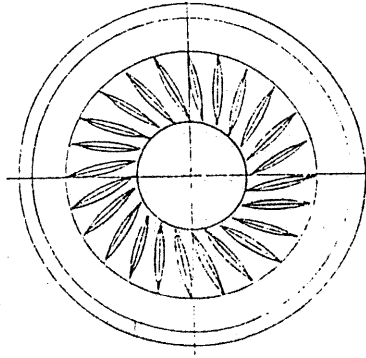
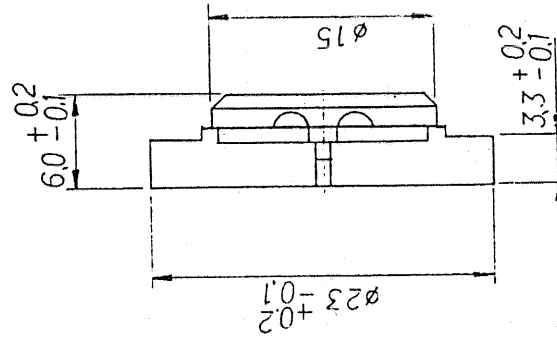

MERRY ELECTRONIC CO., LTD.		MODEL NO.	MAT. L	UNIT	SCALE	TOL. E	PART. NO.
TITLE 外觀圖		DSH305	FINISH	MM	2:1	± 0.1	
SIZE		APPROVE	QA CHECK	ENGINEER	RAFTMAN	75	DRAWN NO.
				JIM		5.	B305V001
						12	SHEET OF
							12